



# SEALTEK

- Mechanical Seals
- Seal Support Systems
- Braided Packing
- Injectable Packing
- Flat Gaskets
- Maintenance Products

*PRODUCT CATALOG*

**SEALING BEYOND EXPECTATIONS**

*Sealing Devices and Industrial Maintenance Solutions*

**PRODUCT CATALOG**

**CONTACT US!**



SEALTEK® srl

Via Germania, 31

35010 VIGONZA (PD) Italy

Tel. +39 049 8930536-8932178

Fax +39 049 8931723

[www.sealtek.com](http://www.sealtek.com)

e.mail: [info@sealtek.com](mailto:info@sealtek.com)



	Page n.
Contact us!	2
Materials identification and coding	5
Product lines	6
<b>Mechanical seals</b>	
STYLE 600 - Sleeveless cartridge seals	8
STYLE 688 Split Seal	12
Diamond coating technology	13
API SEALS - Type A, Arrangement 1	14
API SEALS - Type A, Arrangement 2 and 3	15
Modular System cartridge seals	16
Metal bellows mechanical seals	18
Customized mechanical seals	20
Component seals	21
OEM Mechanical seals	23
Seal Support Systems	24
<b>Packing and Gaskets</b>	26
<i>Braided packing</i>	27
Zero leakage system	35
Flat gaskets	39
<b>Maintenance and repair products</b>	43
Seal-Tex	45
Online pipeline repair and protection tapes	46
Industrial Maintenance Chemicals	47
Special products	48
Lubricants	50
Coatings	52
Cleaners	54
Ultra Metal System	57



SEALTEK

# MATERIALS IDENTIFICATION AND CODING

With the emergence of new technologies and materials the need to unify and rationalize the identification of seals has become increasingly important. The **EN 12756 System**, has now replaced the **Deutsche Industry Norm DIN 24962**, and the **French NFE 29-991**, with the aim of defining the critical dimensions of the pump housing, the seal itself and the materials of construction.

SINGLE SEALS	Material Referring Letters
Rotary Ring	<b>1</b>
Stationary Ring	<b>2</b>
Secondary Seals	<b>3</b>
Spring(s)	<b>4</b>
Construction Material	<b>5</b>

DOUBLE SEALS	Product Side	Atmospheric Side
Rotary Ring	<b>1</b>	<b>1</b>
Stationary Ring	<b>2</b>	<b>2</b>
Secondary Seals	<b>3</b>	<b>3</b>
Spring(s)	<b>4</b>	
Construction Material	<b>5</b>	

## STANDARD MATERIALS

CODE	1, 2 FACE MATERIALS	CODE	3 SECONDARY SEALS MATERIALS	CODE	4, 5 SPRING AND CONSTRUCTIONS MATERIALS
A	Antimony filled carbon	E	Ethylene propylene rubber	G	1.4571 CrNiMo-Steel (316Ti)
B1	Resin coated carbon	P	NBR	G1	1.4462 CrNiMo-Steel (Duplex)
D1	8µ diamon coated SiC	V	Fluorocarbon rubber	G4	1.4501 CrNiMoCu steel, Superduplex
D2	16µ diamon coated SiC	X	TFE/P - FEPM	G7	1.4410 CrNiMoN steel, Superduplex
G	CrNiMo-Steel	K	FFKM	M	Hastelloy C-4
U2	TC - tungsten carbide nickel binder	M1	FKM, double PTF wrapped	M4	Monel alloy K500
U22	TC tungsten carbide nickel binder shrunk fitted	M2	EPDM, double PTF wrapped	M5	Hastelloy C276
Q1	SiC sintered silicon carbide	M5	FKM, FEP wrapped	M6	Inconel 718
Q2	SiC reaction bonded silicon carbide	M7	FKM, double PTFE wrapped/PTFE, solid	F	1.4301 (304)
Q3	Graphite-loaded SiC	T	PTFE	T2	Pure Titanium
Q12	SiC sintered silicon carbide shrunk fitted	G	Pure graphite	T3	Inconel 625
Q22	SiC silicon carbide RB shrunk fitted			T5	Incoloy 800
V	Aluminum dioxide (ceramic) > 99%			T6	AM 350 special alloy
V2	Aluminum dioxide (ceramic) > 96%				
Y1	PTFE, fiberglass reinforced				



### "SLEEVELESS" MECHANICAL SEAL LINE

**S**ealtek® is the first and only mechanical seal manufacturer to offer a complete line of conical seals featuring superior performances and lower costs than cartridge seals of previous generations which are still the standard for all other brands.

**Sealtek®** patented design features greater compensation for misalignment, self-cleaning and self-cooling properties. This revolutionary design, which allows for easy customization for various stuffing boxes, has proven over the course of years to handle the majority of industrial applications: from the basic single seal designed in 2006, the line has evolved to include a double, split, heavy duty, high pressure and non-metallic variant.

The original design has since then been changed to also allow the use of quench even in the simplest configuration.



### API 682 MECHANICAL SEALS

**B**y using only the highest quality materials and providing even more controls and certificates than required by the API 682 regulations, **Sealtek®** is able to offer a complete line of mechanical seals for Oil & Gas upstream and downstream applications, with considerably lower delivery times than the market average.

To top up its API 682 offering, **Sealtek®** also designs and provides all the necessary auxiliary systems, such as barrier fluid vessels, valves, heat exchangers, transmitters and indicators, by choosing the components from the best suppliers, some of whom are included within the Sealtek® industrial group.

### MECHANICAL SEALS FOR A WIDE RANGE OF APPLICATIONS

**S**ealtek® offers one of the World's largest selections of mechanical seals, covering almost the totality of the market. Among the **Sealtek®** range: OEM and component seals of the most common design, cartridge seals according to EN, ISO, JIS or ANSI standards, metal bellows seals, heavy slurry seals, dry running gas seals, mixers seals. What makes **Sealtek®** unique in the market is our ability to craft custom-designed solutions, even for very small quantities. The end user's requirement of today becomes our product of tomorrow.



### MODULAR SYSTEM

**M**odular System is **Sealtek's** signature line of cartridge-mounted mechanical seals. By using the same parts to assemble several different models, **Sealtek®** is able to offer any seal among the standard sizes and materials with immediate, off-the-shelf delivery. At the same time, the modular components enable the end user to lower the stock of spare parts, as the same repair kit can be applied to a large number of seal models of the same size.

## PACKING AND GASKETS

**S**ealtek® manufactures a very wide array of flat gaskets made of hi-tech materials, from graphite to aramid fibers and bi-axial PTFE, and stuffing box packings, either braided or injectable. The braided packing line features over 40 types to meet the widest possible variety of applications with the usual industry leading **Sealtek** quality standards.



## PIPELINES ONLINE REPAIR SYSTEMS

**L**eakage from pipelines has always been a major issue for all industries, from Water/Wastewater to Chemical and Oil & Gas. **Sealtek**® has developed a complete line of products to perform quick, safe and long-lasting repairs on pipeline leakages without the need of shutting the lines. The Seal-Tex and Self-Seal tapes, in conjunction with the Leak-3 and GF-HD pastes, have successfully allowed savings beyond imagination to several important factories, power plants and refineries, and are now a part of the must-have equipment for emergency leakage containment. Seal-Tex is certified according to ASME PCC-2/2008.

## INDUSTRIAL MAINTENANCE PRODUCTS

**A**ll **Sealtek**® coatings, lubricants, cleaners and metal-ceramic compounds have one feature in common: they are manufactured without compromise on quality. We believe that an effective industrial maintenance program cannot be achieved without effective and efficient modern products which meet or exceed the environmental regulations that are being enforced all over the World. All **Sealtek**® Industrial Maintenance Products are manufactured in Italy under the most rigid safety standards, and are the perfect tools for value creation in plant maintenance.



## ZERO LEAKAGE SYSTEM

**I**njectable packing, known as Zero Leakage System, allow to refill the stuffing box without dismantling the valve or pump, and are the World's only products of this kind to be manufactured with 90% virgin fibers only. Other similar products are made with the leftovers of used fibers. The saving in terms of leakage, man-hours and machine downtime makes ZLS the ideal sealing device for continuous operations.

# SLEEVELESS CARTRIDGE SEALS



## STYLE 600SL

This revolutionary seal design is the result of the most intensive engineering design study imaginable. The first real innovation in the sealing market for many years.

Until now all mechanical cartridge seals have been designed with an integral shaft sleeve. This revolutionary sleeveless design allows for installation on pumps where it was previously considered impossible to install a cartridge mounted seal.

The sleeveless design also allows for greater radial run-out of the shaft. The 600SL is first cartridge mechanical seal to incorporate a conical stuffing box design, allowing it to greatly improve seal life in slurry and dirty fluid applications. With no seal parts inside the stuffing box, slurry contamination cannot clog the seal greatly increasing seal life.

This new seal also incorporates a gland plate with flushing connection and large, solid seal faces manufactured from sintered materials mounted on flexible elastomers, which also act as shock absorbers. This seal offers great reliability under the harshest of working conditions.

The 600SL offers the user real benefits in terms cost savings of new seals, spare parts kits and most importantly **MTBF!** This is the only real innovation in the sealing market for many years!

## PATENT: EU1370506

Materials		Technical Data	
<b>Metal parts</b>	Aisi 316 L DIN 1.4571*	<b>Pressure</b>	Vacuum 700 mm Hg ÷ 3,5 MPa**
<b>Elastomers</b>	FKM - EPDM - FFKM - FEPM - TTV	<b>Temperature</b>	Up to elastomer limit. FKM: +205°C E.P.R.: +150°C FFKM: +315°C
<b>Sliding faces</b>	A - B - Q1 - Q2 - U2	<b>Speed</b>	25 m/sec Depending on materials of sliding faces
<b>Springs</b>	Hastelloy* C - 276 DIN 2.4819	<b>Dimensions</b>	25-100mm ***

\*Other materials available upon request \*\*Upon shaft diameter and speed \*\*\*Other sizes available.

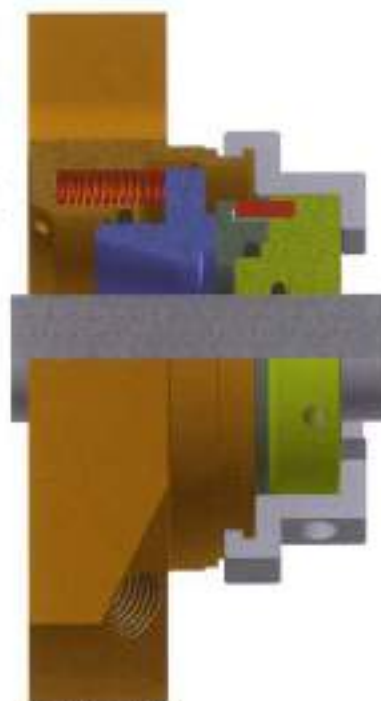

STYLE 600SL

Dynamic elastomer on fretting-free sintered ceramic materials face

Monolithic and hydraulically balanced stationary faces, conical shaped for greater shaft misalignment tolerance and to prevent clogging

No seal parts inside pump stuffing box

Static elastomer with shock-absorbing feature

Gland with conical stuffing box and flush connection features

Monolithic, solid rotary face

Extremely compact dimensions

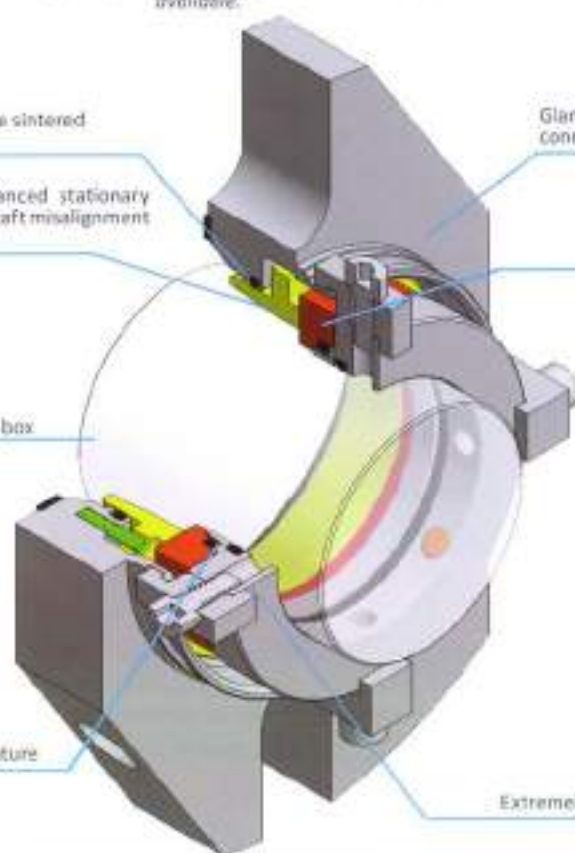

STYLE 600SL



## STYLE 606 DFS

New conception double cartridge seal which makes the best use of the recent technology developed for the Style 600SL seals and widens its applications and performances.

The Style 606 DFS is equipped with its own conical extension of the stuffing box in order to provide the longest possible MTBF available in the toughest applications.

The seal faces are designed by means of the most advanced FEA technology, with double balance.

Style 606 DFS features multiple springs out of the pumped fluid, is extremely compact but able to withstand radial misalignments up to 4°.

Equipped with standard pumping ring, the Style 606 seal can be installed in almost every application, even heavy duty pumps, reactors, and mixers.

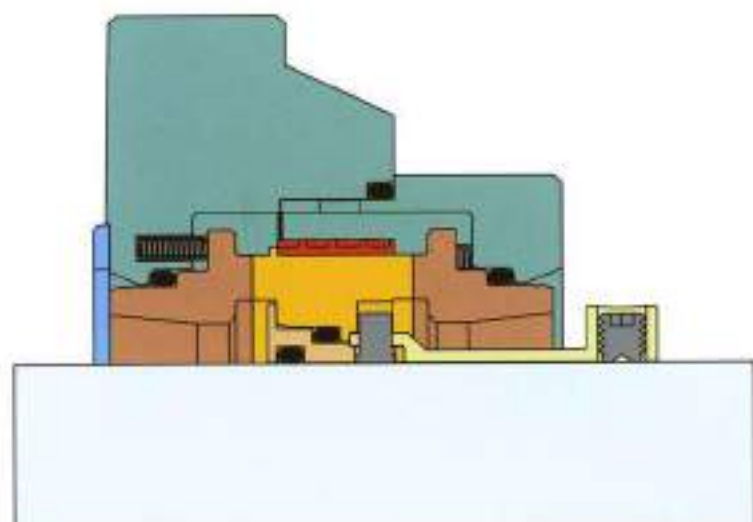

STYLE 606 DFS

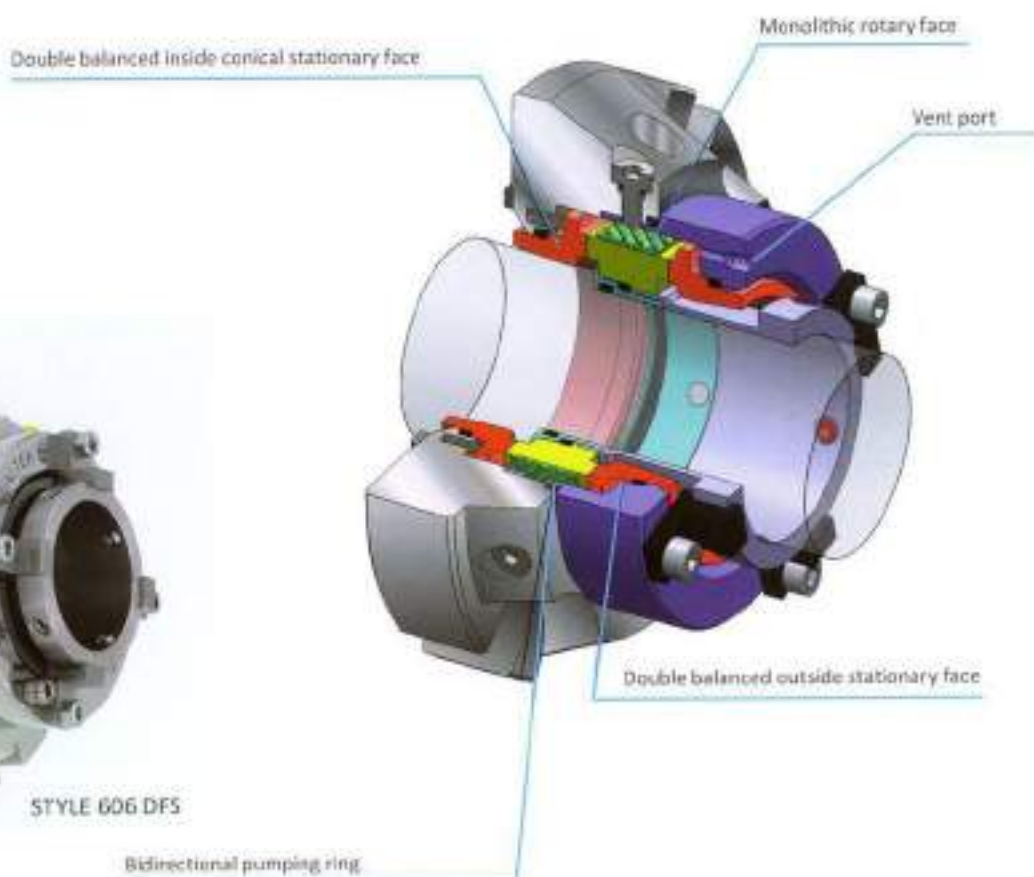

STYLE 606 DFS

# SLEEVELESS CARTRIDGE SEALS



## 600 Q / 600 FX

This variant includes two additional connections for quench and drain. Style 600Q is equipped with a lip seal for leak-proof continuous quench (Plan 62), while Style 600FX replaces the lip seal with a close tolerance fixed bushing which can be used for quench containment as well as for leakage collection (Plan 65). Particularly suitable for crystallizing and polymerizing fluids, where environment control outside the seal faces is necessary.

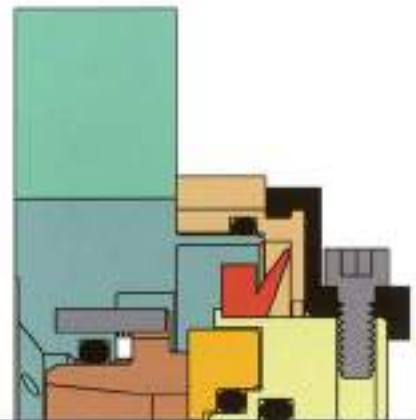

STYLE 600 Q

## 600 NMT

For all applications involving aggressive chemicals, Style 600NMT is a more efficient and more effective alternative to exotic alloys such as Super Duplex or Hastelloy C276, which are drastically outperformed by this revolutionary design where the wetted parts are in sintered silicon carbide to provide total chemical resistance and enhanced abrasion resistance for just a fraction of the cost.

The NMT technology can be applied to our other sleeveless mechanical seals.

Style 606NMT is the double seal specifically designed for dangerous aggressive chemicals, and Style 600HD-NMT is the ultimate solution for heavy abrasive slurries typically found in the mining and paper industry.

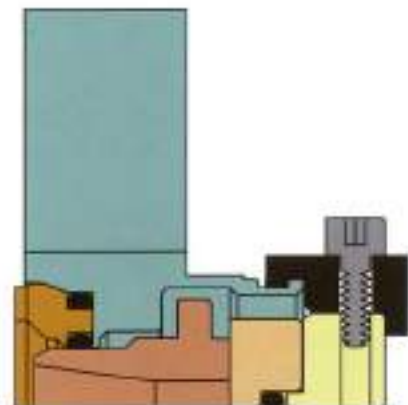

STYLE 600 NMT



STYLE 600 NMT



STYLE 600 HD

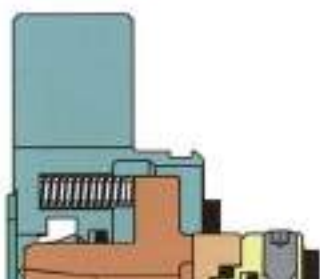

STYLE 600 HD

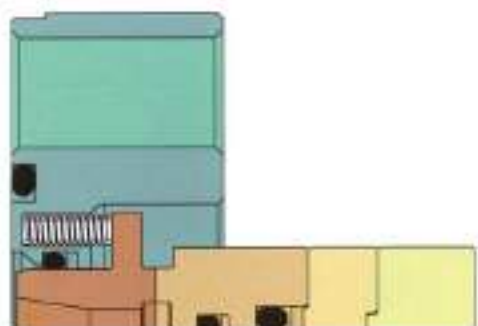

STYLE 600 HP



STYLE 600 HP

### 600 HD

**S**tyle 600HD is a more robust design of the original Sleeveless seal, specifically made for heavy duty applications requiring a sturdy seal to withstand heavy mechanical shocks.

Large driving pins and anti-rotation pins ensure a greater torque resistance, and the multiple springs are as well oversized. With the addition of the revolutionary outside quenching ring, the seal can be quickly upgraded for applications involving crystallizing or polymerizing fluids.

### 600 HP

**V**ariant for high pressure applications, able to withstand working environments of up to 100 bar. The special shape of sliding faces designed through the most advanced F.E.M. systems, allows safe working at very high pressure without distortion and with extreme PV factor.

Thanks to its specific design and use of advanced materials to reduce seal faces load and friction, it can be successfully installed in boiler feed pumps, booster pumps, extruders and hydrocracking units.

# SLEEVELESS CARTRIDGE SEALS



## STYLE 688 SPLIT SEAL

Style 688 is the latest result of Sealtek research and engineering efforts, and the most advanced split seal in the World.

While still keeping all the features and benefits of the acclaimed Style 600SL cartridge-mounted mechanical seal, which has introduced to the market the concept of conical extension of the stuffing box, Style 688 requires no more effort than joining the two parts together and tightening the gland bolts. This dramatically cuts the installation time from hours to minutes, reduces the machine downtime and lowers the risk of installation-related seal malfunctions.

Style 688 can be applied on a wide range of applications and is the ideal seal for pumps which are difficult to disassemble or are located in hard to reach positions.

The Style 688M Semi-Split version includes a one-piece gland which, after the initial installation, allows the use of split replaceable parts, thus removing the need to dismantle the pump for seal maintenance, while granting lower costs and higher reliability.

### Technical Data

Pressure	Max 2.5 MPa* (362 PSI)
Temperature	Max 120°C (248°F)
Speed	Max 20 m/s (44.74 mph)

\*Actual pressure limit may vary according to shaft size, process fluid and material of seal faces.



STYLE 688 SPLIT

### LEGENDA:

- 1 Springs out of the fluid;
- 2 Conical stationary face;
- 3 Pre-assembled and pressure tested;
- 4 Integrated flush ports;
- 5 Balanced seal design;
- 6 All replaceable parts are located outside the gland.

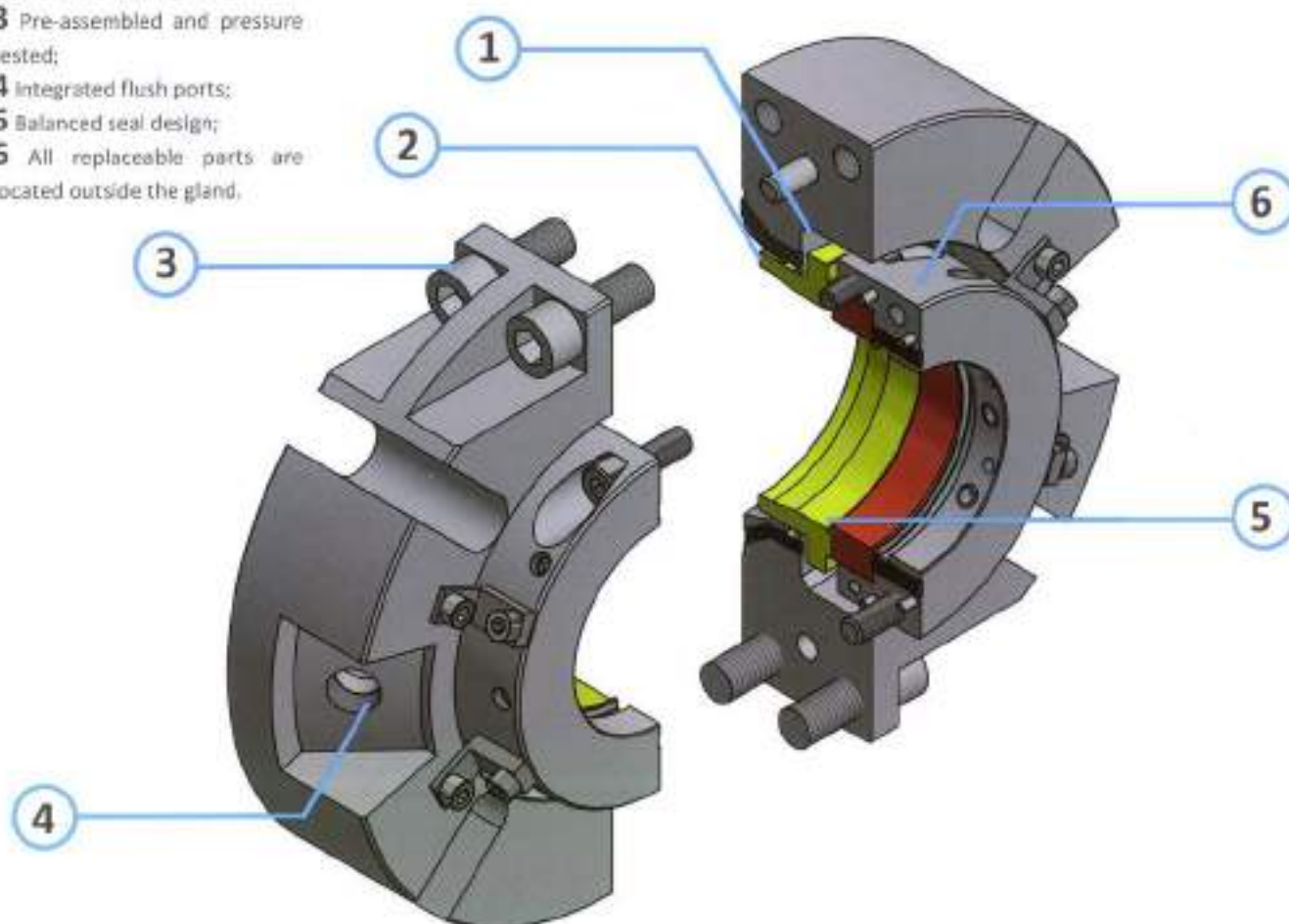

## DIAMOND COATING TECHNOLOGY

**D**iamond-coated mechanical seal faces greatly outperform other materials in terms of friction, heat generation and dissipation, power absorption and *tolerance to dry-running*.

Although not made for continuous dry running in most applications, diamond faces completely eliminate the threat of seal damage for occasional short-term lack of seal lubrication. Their tribological properties guarantee remarkable *power savings*, with big economic and environmental improvements on all industrial operations. Such savings usually reach over 50% of the total mechanical seal energy consumption.

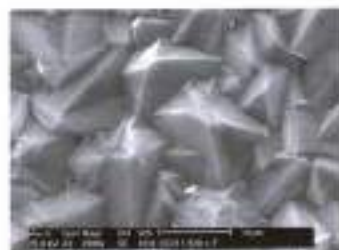

Polycrystalline diamond (electron microscope).

The diamond coating technology for mechanical seals is rapidly gaining confidence among users worldwide, not all coatings are alike. Sealtek is proud to provide a *complete technical support* when selecting the most suitable coating for each application, in order to always offer the most cost-effective solution. A few examples of the several available types of coatings include:

- STANDARD COATING:** A 8µm-thick layer of CVD diamond provides the *optimal solution for costs optimization*. Standard diamond can be paired with other materials to provide extremely low friction coefficients at very reasonable prices.
- HEAVY DUTY COATING:** 16µm or 24µm layer of polycrystalline diamond, extremely suitable for *low viscosity slurries* that would usually provide an insufficient lubrication to the mechanical seal without large quantities of expensive flushing. Excellent for the paper and mining sector, or any application involving abrasive and dense slurries.
- SOFT COATING:** Smoother surface, providing a superior seal face flatness. This coating greatly reduces the seal's friction coefficient when *operating with high viscosity fluids*, such as hot water or flashing hydrocarbons, which would cause unacceptable leakage with other types of diamond.
- AMORPHOUS COATING:** While other coatings always require a silicon carbide face as base, this technology can be applied on tungsten carbide, when its mechanical resistance is needed for *crystallizing or polymerizing fluids* applications.



Seal face coated with CVD diamond, as it appears after 10 hours of dry running at 1500 rpm.

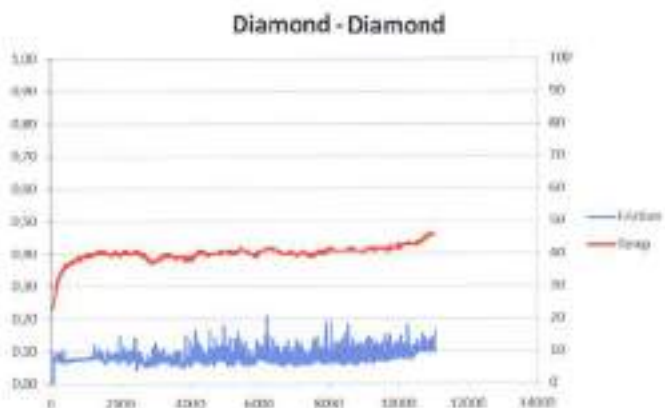
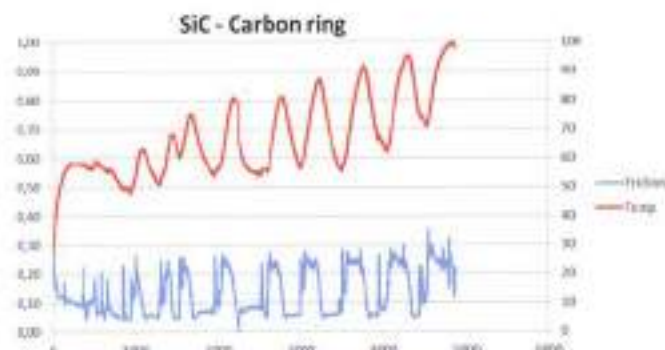

# API SEALS Type A Arrangement 1



## STYLE 750 API TYPE A, ARRANGEMENT 1

- Style 750 API features the reliable and time-tested Style 550 design, with cartridge and sleeve to match API 682 standard.
- Multiple springs out of the fluid, and fretting-free dynamic O-ring working on the seal face.

### Technical data

Pressure	40 bar
Temperature	-40°C + +305°C
Speed	18 m/sec
Special features	Fixed or floating throttle bushing

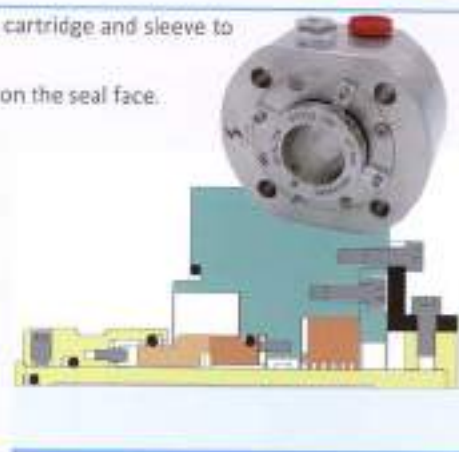

## STYLE 701 API TYPE A, ARRANGEMENT 1

- Rotary single API682 seal for clean fluids applications.
- Medium (Style 702) and high (Style 703) pressure design rotary faces available.
- Available with floating or fixed throttle bushing.

### Technical data

Pressure	Up to 21 bar (702: 42 bar; 703: 70 bar)
Temperature	-40°C + +305°C
Speed	25 m/sec
Special features	Pumping ring for Plan 23 applications available (701P)

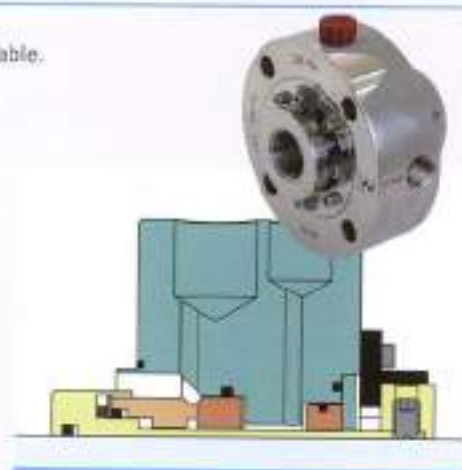

## STYLE 730 API TYPE A, ARRANGEMENT 1

- Single API682 seal, with single spring independent from rotation.
- Available with floating or fixed throttle bushing.

### Technical data

Pressure	Up to 70 bar
Temperature	-40°C + +305°C
Speed	23 m/s
Special features	Pumping ring for Plan 23 applications available (730P)



# SEALTEK API SEALS Type A Arrangement 2, 3

## STYLE 755 API TYPE A, ARRANGEMENT 2 AND 3

- Double rotary API682 seal
- Multiple springs out of the fluid
- Fretting-free dynamic O-ring.

### Technical data

Pressure	40 bar
Temperature	-40°C + +305°C
Speed	18 m/s
Special features	Equipped with internal pumping ring

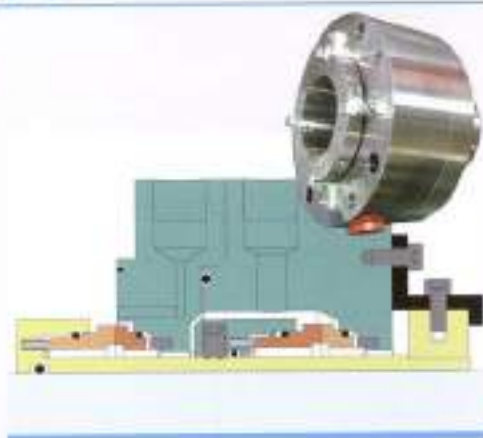

## STYLE 711 API TYPE A, ARRANGEMENT 2 AND 3

- Double rotary API682 seal for clean fluids applications.
- Medium (Style 712) and high (Style 713) pressure design rotary faces available.
- Internal pumping ring for barrier fluid.

### Technical data

Pressure	Up to 305 PSI (712: 42 bar; 713: 70 bar)
Temperature	-40°C + +305°C
Speed	25 m/s
Special features	Pumping ring for Plan 23 applications available (711P)



## STYLE 777 API TYPE A, ARRANGEMENT 2 AND 3

- Double stationary API682 seal with multiple springs out of the fluid.
- Symmetric design maximizes the MTBF.

### Technical data

Pressure	Vacuum 700 mm Hg + 25 Kg/cm <sup>2</sup>
Temperature	-40°C + +305°C
Speed	25 m/s
Special features	Equipped with internal pumping ring

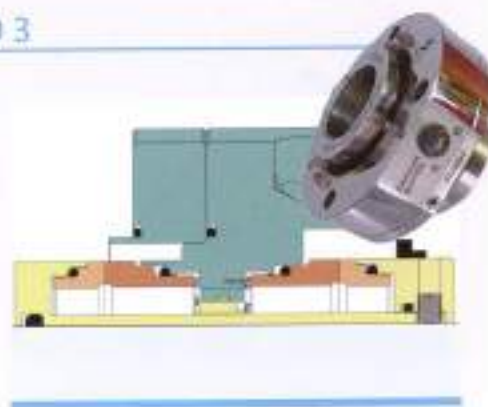

API SEALS Type B and Type C single and double seals also available –  
for further information, please refer to the Sealtek API682 catalogue.

# Modular System cartridge seals



## STYLE 770 SINGLE CARTRIDGE SEAL

- Balanced
- Stationary
- Standard gland
- Same replaceable parts as other Modular System seals

### Technical data

Pressure	0,9 + 25 bar
Temperature	-40°C + +305°C
Speed	25 m/sec

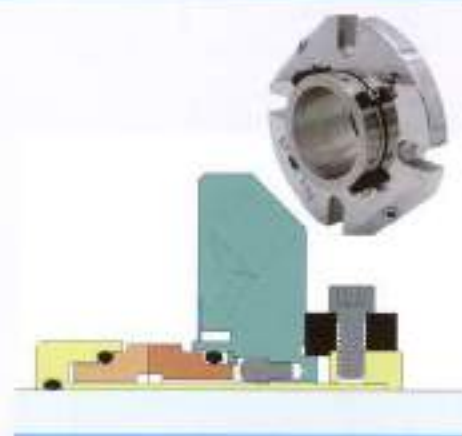

## STYLE 777SO SINGLE CARTRIDGE SEAL FOR QUENCH APPLICATIONS

- Balanced
- Stationary
- Standard gland
- Same replaceable parts as other Modular System seals
- Lip seal for leak-proof continuous quench

### Technical data

Pressure	0,9 + 25 bar
Temperature	-40°C + +305°C
Speed	25 m/sec



## STYLE 777SW DOUBLE CARTRIDGE SEAL

- Balanced
- Stationary
- Standard gland
- Same replaceable parts as other Modular System seals

### Technical data

Pressure	0,9 + 25 bar
Temperature	-40°C + +305°C
Speed	25 m/sec

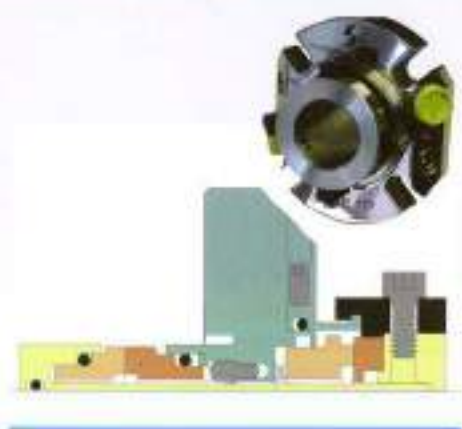



**STYLE 670** SINGLE CARTRIDGE SEAL

- Balanced
- Stationary
- Reduced gland
- Same replaceable parts as other Modular System seals

## Technical data

Pressure	0,9 + 25 bar
Temperature	-40°C + +305°C
Speed	25 m/sec

**STYLE 677RG** DOUBLE CARTRIDGE SEAL

- Balanced
- Stationary
- Reduced gland
- Same replaceable parts as other Modular System seals

## Technical data

Pressure	0,9 + 25 bar
Temperature	-40°C + +305°C
Speed	25 m/sec

**STYLE 677SO** SINGLE CARTRIDGE SEAL WITH QUENCH

- Balanced
- Stationary
- Reduced gland
- Same replaceable parts as other Modular System seals
- Lip seal for leak-proof continuous quench

## Technical data

Pressure	0,9 + 25 bar
Temperature	-40°C + +305°C
Speed	25 m/sec



# Metal bellows



## STYLE 580 METAL BELLOWS ROTARY COMPONENT SEAL

- Metal bellows in AM350.
- Available with Hastelloy C276 bellows and retainer (Style 581)
- Available with AISI 316 retainer and Hastelloy C bellows (Style 582).

### Technical data

Pressure	40 bar
Temperature	-40°C + +305°C
Speed	15 m/sec
Metal bellows material	T6

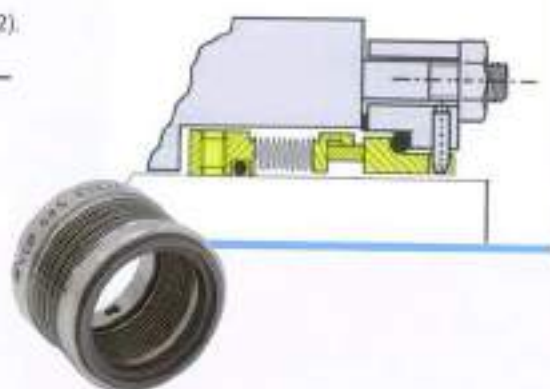

## STYLE 780 SINGLE CARTRIDGE MOUNTED ROTARY METAL BELLOWS SEAL

- Metal bellows available in wide range of materials.
- Available with stationary bellows (Style 784),
- Available with lip seal for leak-proof quench (Style 780Q), or with throttle bushing (Style 780FB).

### Technical data

Pressure	25 bar
Temperature	-40°C + +305°C
Speed	20 m/sec
Metal bellows material	G - T6 - T1 - M5

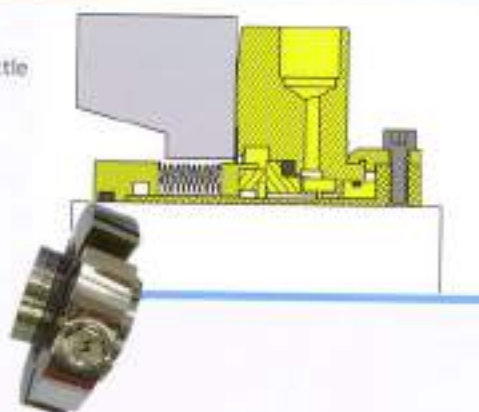

## STYLE 788 DOUBLE CARTRIDGE MOUNTED ROTARY METAL BELLOWS SEAL

- Metal bellows available in wide range of materials.
- Available with stationary bellows (Style 787).

### Technical data

Pressure	21 bar
Temperature	-40°C + +305°C
Speed	25 m/sec
Special features	G - T6 - T1 - M5

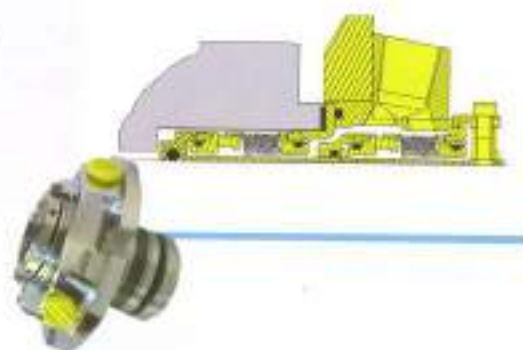

**STYLE 590** METAL BELLOWS ROTARY COMPONENT SEAL

- For high temperature or cryogenic applications
- Secondary seals in graphite.
- Available with driving pin and double ply bellows for higher pressure resistance (Style 591)

## Technical data

Pressure	590: 30 bar – 591: 50 bar
Temperature	380°C
Speed	590: 20 m/sec – 591: 15 m/sec
Metal bellows material	590: T8 – 591: T6 Double Ply

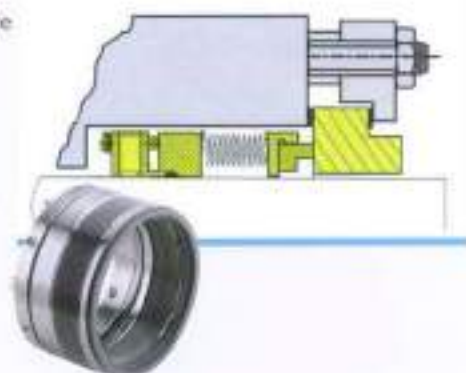
**STYLE 790** SINGLE CARTRIDGE MOUNTED ROTARY METAL BELLOWS SEAL

- Metal bellows available in wide range of materials.
- Secondary seals in graphite.
- Available with stationary bellows (Style 794)
- Available with lip seal for leak-proof quench (Style 790Q), or with throttle bushing (Style 790FB).

## Technical data

Pressure	21 bar (Double ply: 65 bar)
Temperature	-60°C + +450°C
Speed	25 m/sec
Metal bellows material	G - T6 - T1 - M5

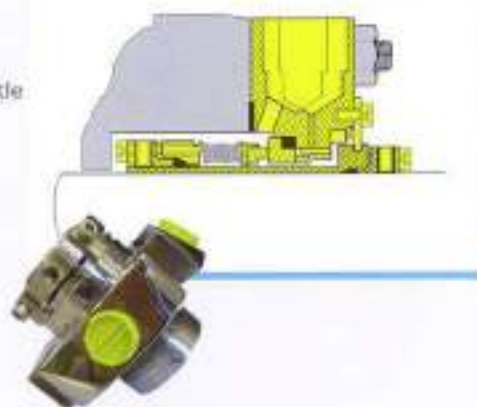
**STYLE 798** DOUBLE CARTRIDGE MOUNTED ROTARY METAL BELLOWS SEAL

- Metal bellows available in wide range of materials.
- Secondary seals in graphite.
- Available with stationary bellows (Style 797).

## Technical data

Pressure	21 bar (Double ply: 65 bar)
Temperature	-60°C + +450°C
Speed	25 m/sec
Metal bellows material	G - T6 - T1 - M5

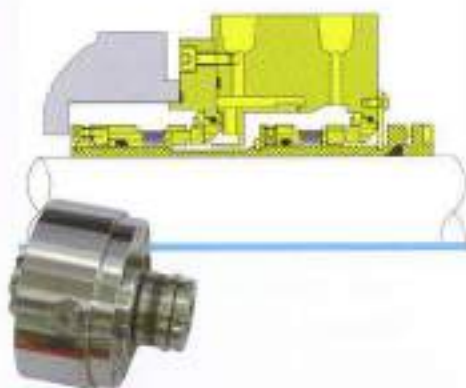



## MECHANICAL SEALS FOR MIXERS

**S**ealtek® manufactures a wide range of mechanical seals for mixers and agitators, making the best use of its technology to provide innovative solution for the most demanding applications. Sealtek® mixers seal stand out for their extremely high tolerance to shaft deflection and misalignment, and for the enhanced resistance to dry running given by the latest generation seal faces materials.

Mixer seals can be manufactured according to the DIN 28138 standard, and can be installed in steel vessels according to DIN 28136, mounting flanges according to DIN 28141, and are compatible with DIN 28154 agitators shaft ends.

All the models can be supplied with the addition of radial bearings, and can be customized to fit specific applications.

## CUSTOMIZED MECHANICAL SEALS

**T**he first principle of the Sealtek® philosophy is: the customer must never be forced to modify his pump. Whenever an application cannot be properly sealed with standard solutions, the Sealtek® R&D department is ready to modify the existing designs to suit the customer's specific requirements, or eventually create new models from scratch, regardless of the quantity involved.

Sealtek® representatives around the World are available to provide direct assistance and troubleshooting for sealing applications, gather the data required to design the customized proposal and assist the customer until a satisfactory sealing solution is found.



Sealtek® Style 606 3D for SCAM vacuum pumps.



Sealtek® Style 600, for reactors.

### STYLE 400 Outside rotary component seal

- No metal parts in contact with fluid
- Clamping ring for installation on any shaft material
- Full solid seal faces

#### Technical data

Pressure	12 bar
Temperature	-40°C + +305°C
Speed	20 m/sec
Special features	Interchangeable seal face

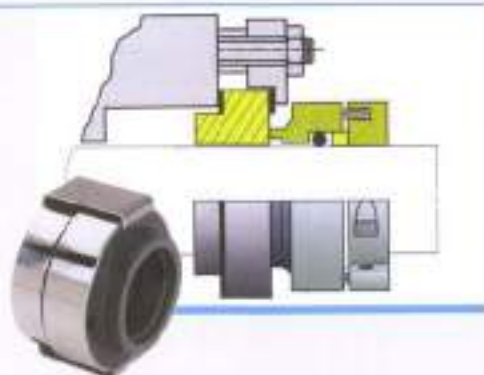

### STYLE 410 Outside rotary component seal with PTFE bellows

- No metal parts in contact with fluid
- Clamping ring for installation on any shaft material
- No dynamic o-ring

#### Technical data

Pressure	12 bar
Temperature	-40°C + +230°C
Speed	16 m/sec
Bellows material	T

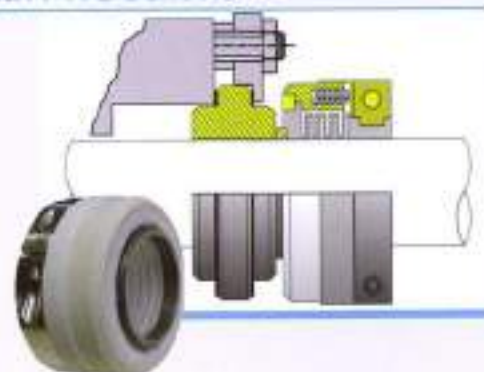

### STYLE 520 Elastomeric bellows rotary component seal

- No dynamic o-ring
- Enhanced misalignment tolerance
- Independent from shaft rotation

#### Technical data

Pressure	12 bar
Temperature	-20°C + +204°C
Speed	10 m/sec
Bellows material	P - E - V

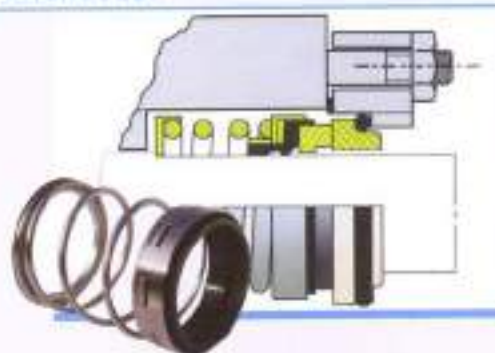

### STYLE 522 Elastomeric bellows rotary component seal

- No dynamic o-ring
- Length according to L1K
- Independent from shaft rotation
- Elastomeric bellows protected by a metal body

#### Technical data

Pressure	15 bar
Temperature	-20°C + +204°C
Speed	13 m/sec
Bellows material	P - E - V

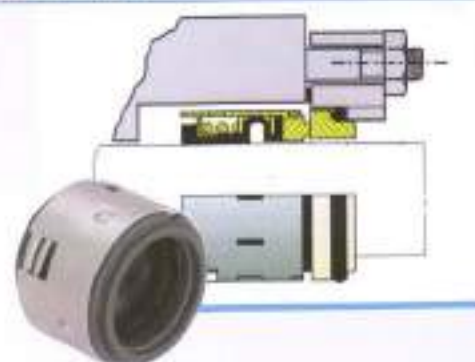

# COMPONENT SEALS



## STYLE 523 Elastomeric bellows rotary component seal

- No dynamic o-ring
- Available with length according to L1K (Style 524)
- Independent from shaft rotation

### Technical data

Pressure	12 bar
Temperature	-20°C + 204°C
Speed	10 m/sec
Bellows material	P - E - V

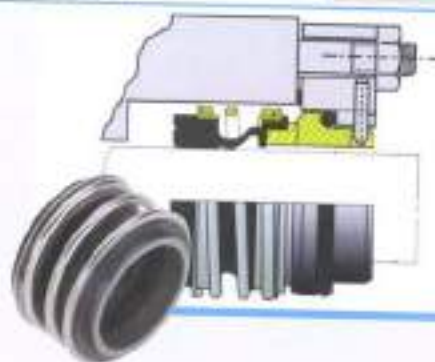

## STYLE 530 Single spring rotary component seal

- Dependent on shaft rotation
- Large volume seal, inexpensive

### Technical data

Pressure	10 bar
Temperature	-40°C + 305°C
Speed	10 m/sec

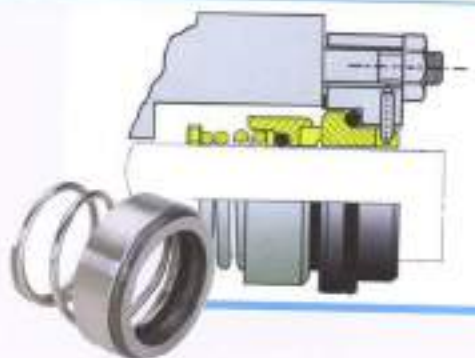

## STYLE 531 Heavy duty single spring rotary component seal

- Independent from shaft rotation
- Very robust design with cylindrical oversized spring

### Technical data

Pressure	16 bar
Temperature	-40°C + 305°C
Speed	20 m/sec

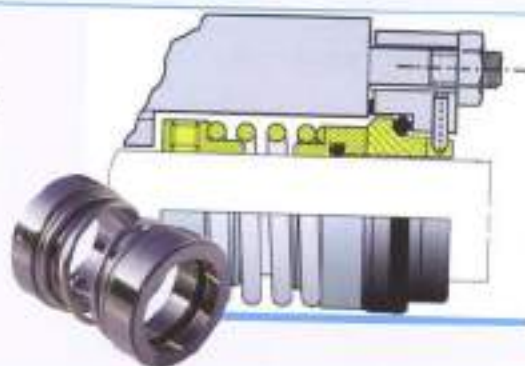

## STYLE 550 Multiple springs rotary balanced component seal

- Balanced
- Fretting-free dynamic o-ring
- Springs out of the fluid
- Replaceable seal faces

### Technical data

Pressure	40 bar
Temperature	-40°C + 305°C
Speed	18 m/sec

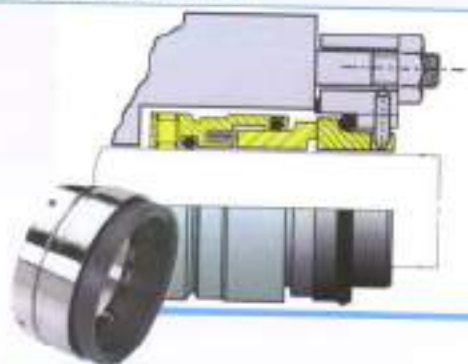

### STYLE 551 Wave spring rotary balanced component seal

- Balanced
- Length according to L1K
- Spring out of the fluid

#### Technical data

Pressure	25 bar
Temperature	-40°C + +305°C
Speed	15 m/sec

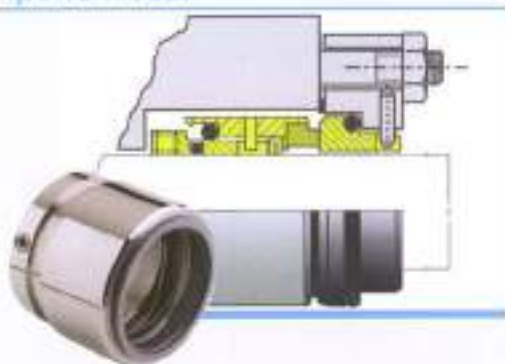

### STYLE 557 Wave spring rotary component seal

- Available in balanced version (Style 557B)
- Length according to L1K
- Replaceable seal faces

#### Technical data

Pressure	16 bar
Temperature	-40°C + +305°C
Speed	20 m/sec
Special features	Available in double seal configuration

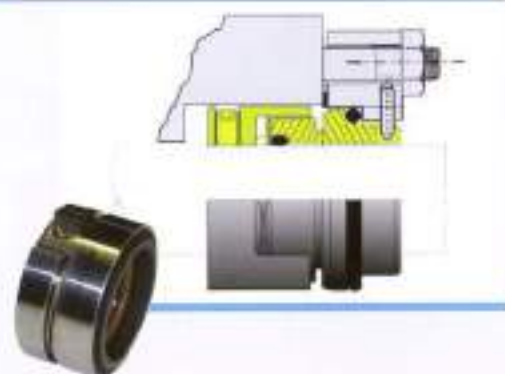

### STYLE 558 Multiple springs rotary component seal

- Available in balanced version (Style 558B)
- Available with PTFE wedge instead of o-ring (Style 559 and Style 559B)
- Length according to L1K
- Replaceable seal faces

#### Technical data

Pressure	U = 15 bar ; B = 35 bar
Temperature	-40°C + +305°C
Speed	20 m/sec
Special features	Available in double seal configuration

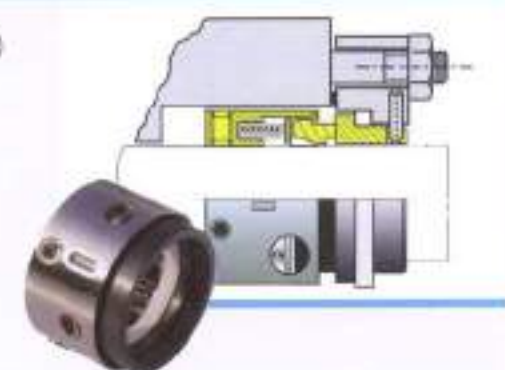

### OEM Mechanical Seals

Sealtek® manufactures mechanical seals with specific design for installation on pumps whose seal chamber is not compliant with international standards, such as Flygt, Grundfos, Fristam, Hidrostal and several other brands. While the size is tailored to fit such specific pumps, the materials and the design are selected to offer a higher quality alternative to the original. Please contact your nearest Sealtek® distributor for more information about the complete Sealtek® OEM seals line.





## API PLAN 53A

External reservoir providing pressurized barrier fluid to double mechanical seals. Pressurization is made through outside nitrogen source. Unpressurized version can be used for Plan 52.

### SEALTEK® Api Plan 53A includes

- Style 300 or Style 300-API vessel
- Optional cooling coil for vessel
- Level switch / transmitter
- Pressure switch / transmitter
- Optional recirculation pump for thicker fluids
- Base frame, pipes, valves and fittings



## API PLAN 53B

External reservoir providing pressurized barrier fluid to double mechanical seals for high pressure applications. Pressurization is made through a bladder filled by means of nitrogen charging kits.

### SEALTEK® Api Plan 53B includes

- Bladder accumulator of standard API682 sizes
- Pressure indicator
- Pressure switch / transmitter
- Temperature indicator
- Manual refill pump
- Water-cooled (Style 342), air-cooled (Style 343) or finned pipe heat exchanger
- Optional recirculation pump for thicker fluids
- Base frame, pipes and fittings



## API PLAN 53C

External reservoir providing pressurized barrier fluid to double mechanical seals for fluctuating pressure applications. Pressurization is made through a reference line from seal chamber and a piston booster.

### SEALTEK® Api Plan 53C includes

- Piston booster of standard API682 sizes
- Pressure indicator
- Level or piston position indicator
- Level or piston position switch / transmitter
- Differential pressure switch / transmitter
- Temperature indicator
- Water-cooled (Style 342) or finned pipe heat exchanger
- Optional recirculation pump for thicker fluids
- Base frame, pipes and fittings





**STYLE 300** Thermosiphon system

Buffer/barrier fluid tank in stainless steel for Plan 52 and 53, manufactured according with ASME and PED standards. Stainless steel connections, welded see-through level indicator in borosilicate glass, stainless steel safety valve. Can be customized with a wide range of accessories, including refilling unit and cooling coil. Also available according to API682 standard.

## Technical data

Volume (lt)	5, 7, 8, 12, 18
Operating pressure	30 bar
Operating temperature	-60°C - 200°C
Body material	1.4301 (AISI 304) , 1.4571 (AISI 316Ti)
Cooling capacity (with coil)	1.5kW (4 kW with forced circulation)

**STYLE 330** Light duty thermosiphon system

Buffer/barrier fluid tank in synthetic plastic material. Although extremely economical, this model is capable of covering the large majority of non-API Plan 52 and 53A applications where high temperatures or pressures are not involved. Available with internal magnetic driven pump for improved fluid circulation, quick connectors, pressure gauge, level indicator, thermometer, safety valve.

## Technical data

Volume (lt)	5, 7, 8
Operating pressure	10 bar
Operating temperature	-30°C + +70°C
Body material:	Polychloroethene, SPI - resin identification c.s.3
Metal parts:	DIN 1.4301
Temperature/Level indicator sight-through	Polycarbonate

**STYLE 342** Heat Exchanger

Water-cooled heat exchanger, customizable upon requested heat transfer area, pressure and cooling capacity. Process/barrier fluid is in the shell, while cooling fluid is in inside pipes. Can be provided as stand-alone item or as part of a fully assembled API Plan 21, 22, 23 and 41.

## Technical data

Shell material	DIN 1.4404 ; 1.4571
Gaskets material	PTFE, FKM, Expanded graphite
Heat exchange area	0.6m <sup>2</sup> (standard version)
Heat exchange capacity	36kW (standard version)
Operating temperature	350°C
Operating pressure	16 bar (pipe), 50 bar (shell)

**STYLE 320** Cyclone Separator

Cyclone separator to automatically convey contaminants from process fluid to pump suction. Inside wear parts made in silicon carbide for enhanced abrasion resistance. Available as stand-alone item, or as part of a fully assembled API Plan 31 or 41.

## Technical data

Operating temperature	Up to 125°C
Operating pressure	Up to 62 bar
Pressure differential range	1,3 to 8 bar
Shell material	DIN 1.4404
Insert material	Silicon carbide
Gaskets and o-ring material	FKM



## BRAIDED PACKING *overview*



*"If you believe a high quality packing is expensive, you have yet to experience how much a low quality packing will cost you in the end".*

A high quality fiber from the most reliable manufacturers, a proper impregnation and a perfect braiding are the key factors for the production of efficient and effective gland packing. Several factors can make the difference between a quality product able to withstand a full production cycle with relatively low material wear and a low technology packing which, after an initial saving on the purchase, causes several additional costs during the course of its operational life. Sealtek proudly offers a very wide range of braided packing where every single product is guaranteed to represent the current state of the art of its type.

**X** Packing with irregular size will generate oversized and undersized rings. Excessive friction will take place at the bigger ring and increased leakage will occur at the smaller, thus requiring further adjustment and consequent mechanical stress, resulting in reduced packing lifetime.

**X** Low quality lubricants will cause a greater packing friction, increased sleeve wear and energy absorption, higher demand of cooling fluid.

**X** A quicker wear of the packing rings requires more man-hours to keep leakage under control, and can cause unscheduled maintenance stops and undesirable machine downtime, resulting in additional costs.

**✓** A controlled density packing with uniform ring sizes can maximize the sealing action while at the same time minimizing the required compression, which in turn causes a lower friction on the sleeve and a lower mechanical stress on the packing itself, thus increasing their operational life.

**✓** High quality lubricants reduce friction and heat generation, thus extending packing lifetime and minimizing the need for cooling and the costs for absorbed energy

**✓** Slower packing wear reduces leakage and personnel cost for machine monitoring. A maximized packing lifetime enables the machine to be stopped only for its scheduled maintenance.

While the cost associated with a high quality packing able to stay in place as long as needed can be easily calculated, the effects of an unscheduled maintenance is often difficult to predict and to quantify. Since the cost of the packing itself will happen to be but the smallest part of the total machine operation and maintenance expenditure, it becomes clear how high quality products can avoid or minimize all the other related expenditures and can quickly represent a very rewarding investment for any industrial application.

### PACKING OPERATIONAL COST

- 55% Product loss due to machine downtime
- 25% Value of leaked fluid
- 15% Labor cost
- 5% Packing purchase cost

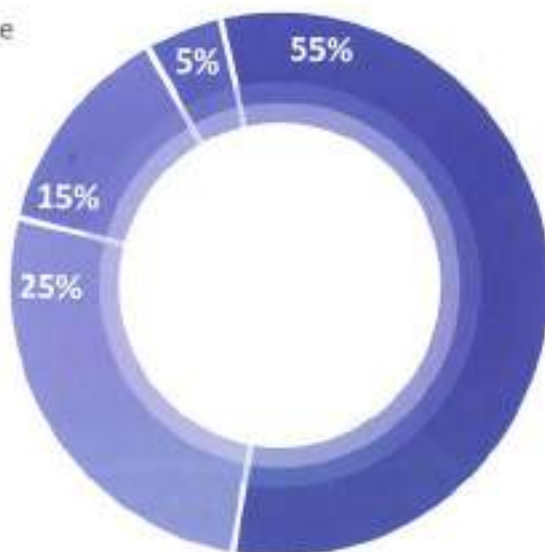

### STYLE 1000 POLYCRYSTALLINE GRAPHITE YARN WITH LIGHT PTFE COATING

100% synthetic crystalline graphite fiber, impregnated with colloidal graphite on synthetic oil.



#### Applications

T °C	-250 + +650			<ul style="list-style-type: none"> <li>• Cryogenic applications</li> <li>• Centrifugal pumps</li> <li>• Chemical industry</li> <li>• Power generation industry</li> </ul>
P bar	80	120	150	
V m/sec	25	10	2	
pH	0 + 14			



### STYLE 1001 CARBOX YARN

Pure preoxidized carbon P.A.N. yarn, impregnated with colloidal graphite on synthetic oil.



#### Applications

T °C	-50 + +500			<ul style="list-style-type: none"> <li>• Medium temperature steam and hydrocarbons valves</li> <li>• Medium temperature steam and hydrocarbons dynamic applications</li> </ul>
P bar	40	100	150	
V m/sec	20	2	1	
pH	2 + 12			



### STYLE 1001/N PANOX YARN

Pure preoxidized carbon yarn, impregnated with colloidal PTFE suspension.



#### Applications

T °C	-40 + +300			<ul style="list-style-type: none"> <li>• Centrifugal and reciprocating pumps</li> <li>• Mixer, agitators</li> <li>• Dryers</li> <li>• Valve stems</li> </ul>
P bar	80	120	150	
V m/sec	25	10	2	
pH	0 + 14			



### STYLE 1002 IMX GRAPHITE YARN

99% Synthetic graphite fiber, impregnated with colloidal graphite on synthetic oil (<2%).



#### Applications

T °C	-80 + +500			<ul style="list-style-type: none"> <li>• Heavy duty high temperature pumps and valves applications</li> <li>• Aggressive fluids</li> </ul>
P bar	25	50	100	
V m/sec	35	4	1	
pH	0 + 14			



# BRAIDED PACKING



## STYLE 1003 IMX GRAPHITE YARN



96% Synthetic graphite fiber and 4% Inconel alloy, impregnated with colloidal graphite on synthetic oil (<2%).

				Applications
T °C	-80 + +500			<ul style="list-style-type: none"> <li>High temperature and high pressure steam valves</li> <li>Top and bottom bull rings in conjunction with Style 1099.</li> </ul>
P bar	-	100	250	
V m/sec	-	2	1	
pH	0 + 14			



## STYLE 1009 COMBIGRAPH YARN



38% synthetic graphite fiber and 62% expanded graphite, impregnated with non-metallic corrosion inhibitor.

				Applications
T °C	-150 + +650			<ul style="list-style-type: none"> <li>Heavy duty, high temperature and high pressure valves, pumps and pistons</li> </ul>
P bar	60	80	150	
V m/sec	30	5	1	
pH	0 + 14			



## STYLE 1009X ULTRAGRAPH YARN

40% carbographite fiber carrier and corners, 60% expanded graphite twisted ribbons, impregnated with non-metallic corrosion inhibitor.

				Applications
T °C	-150 + +750			<ul style="list-style-type: none"> <li>Heavy duty, high temperature and high pressure centrifugal and piston pumps and valves.</li> </ul>
P bar	100	150	300	
V m/sec	30	10	8	
pH	0 + 14			



## STYLE 1023T POLYPROPYLENE JACKET AND PTFE YARN

Acrylic fibers wrapped in PTFE yarns around a silicon core. Can withstand repeated opening and closing cycles of tank lids.

				Applications
T °C	-30 + +160			<ul style="list-style-type: none"> <li>Tank lids and man hatches.</li> <li>Inspection and cleaning covers on tankers carrying any type of liquid cargo in all IMO classes.</li> </ul>
P bar	-	-	20	
pH	0 + 14			



### STYLE 1024 PURE PTFE YARN

100% PTFE braided with High Controlled Density method, impregnated with PTFE dispersion.



#### Applications

T °C	-240 + +260			<ul style="list-style-type: none"> <li>• Strong chemicals on static applications (valves, gates, taps, covers, manholes)</li> <li>• Strong chemicals on low speed centrifugal or reciprocating pumps.</li> </ul>
P bar	50	100	500	
V m/sec	2	1	1	
pH	0 + 14			



### STYLE 1025 FOOD GRADE PURE PTFE YARN

100% PTFE braided with High Controlled Density method; impregnated with food-grade lubricant. Braided in white clean room.



#### Applications

T °C	-200 + +280			<ul style="list-style-type: none"> <li>• Chemical, food and pharmaceutical industry</li> </ul>
P bar	25	100	-	
V m/sec	8	2	-	
pH	0 + 14			



### STYLE 1026 META-ARAMID YARN

Meta-aramid long fibers braided with High Controlled Density method, impregnated with 40% colloidal PTFE.



#### Applications

T °C	-30 + +300			<ul style="list-style-type: none"> <li>• Heavy duty applications</li> <li>• Pulp &amp; Paper applications requiring non-staining white packing</li> </ul>
P bar	60	80	100	
V m/sec	15	5	2	
pH	1 + 13			



### STYLE 1027 PHENOLIC KYNOL® YARN

Phen-Top fibers braided with High Controlled Density method, impregnated with colloidal PTFE and synthetic oil.



#### Applications

T °C	-80 + +260			<ul style="list-style-type: none"> <li>• General applications</li> <li>• Pulp &amp; Paper applications requiring non-staining white packing</li> </ul>
P bar	30	50	80	
V m/sec	25	12	1	
pH	3 + 12			





# BRAIDED PACKING



## STYLE 1028 PURE PTFE YARN

100% PTFE braided with High Controlled Density method, impregnated with colloidal PTFE.

				Applications
T °C	-240 + +280			<ul style="list-style-type: none"> <li>Centrifugal pumps, agitators, mixers and reactors with most chemicals.</li> </ul>
P bar	25	50	100	
V m/sec	8	4	2	
pH	0 + 14			



## STYLE 1028X HIGH SPEED PTFE YARN



100% pure expanded PTFE yarn with encapsulated lubricants, meets FDA CFR 177.550 regulations.

				Applications
T °C	-100 + +280			<ul style="list-style-type: none"> <li>Centrifugal pumps and agitators in chemical, pharmaceutical and food industries.</li> </ul>
P bar	20	30	-	
V m/sec	15	2	-	
pH	0 + 14			



## STYLE 1029 RAMIE YARN



Texturized and treated vegetal fiber, impregnated with colloidal PTFE and synthetic oil.

				Applications
T °C	-30 + +140			<ul style="list-style-type: none"> <li>Marine applications (stern tubes and rudder posts)</li> <li>Pulp &amp; Paper industry</li> </ul>
P bar	20	30	40	
V m/sec	15	6	1	
pH	4 + 11			



## STYLE 1037 KYNOL/ARAMID YARN

Aramid structure, with phenolic-reinforced corners, colloidal PTFE impregnation and silicone rubber core.

				Applications
T °C	-50°C + +200°C			<ul style="list-style-type: none"> <li>Heavy duty large size pumps, mixers and crystallizers</li> <li>Sugar industry</li> <li>Pulp &amp; Paper industry</li> </ul>
P bar	35	50	100	
V m/sec	20	15	2	
pH	2 + 12			



### STYLE 1040 ARAMID YARN

Aramid long fibers, impregnated with 20% colloidal PTFE and synthetic oil.



#### Applications

T °C	-100 + +260			<ul style="list-style-type: none"> <li>Centrifugal and plunger pumps, valves, expansion joints</li> <li>Water, steam, solvents, acids, medium/weak alkalis, oils</li> <li>Marine industry</li> <li>Pulp &amp; Paper industry</li> </ul>
P bar	50	100	200	
V m/sec	20	2	1	
pH	2 + 12			



### STYLE 1042 ARAMID YARN WITH PTFE

Aramid staple fibers, impregnated with 25% colloidal PTFE and synthetic oil.



#### Applications

T °C	-80 + +260			<ul style="list-style-type: none"> <li>Pumps, valves, expansion joints and piston pumps</li> <li>Water, steam, solvents, weak acids and alkalis, oil by-products</li> <li>Chemical, pulp &amp; paper, pharmaceutical, food and water treatment industry</li> </ul>
P bar	30	50	80	
V m/sec	20	12	1	
pH	3 + 12			



### STYLE 1043 ARAMID YARN WITH GRAPHITE

Aramid staple fibers, impregnated with 25% colloidal graphite and synthetic oil.



#### Applications

T °C	-80 + +350			<ul style="list-style-type: none"> <li>Heavy duty high temperature and pressure applications</li> <li>Boiler feed pumps, steam valves and gates.</li> </ul>
P bar	70	150	300	
V m/sec	20	5	2	
pH	2 + 13			



### STYLE 1044 ARAMID YARN WITH PTFE - GRAPHITE

Aramid fibers and interlocked PTFE - graphite, impregnated with colloidal PTFE and synthetic oil.



#### Applications

T °C	-80 + +280			<ul style="list-style-type: none"> <li>Centrifugal and plunger pumps</li> <li>Mixers and reactors</li> </ul>
P bar	70	150	300	
V m/sec	20	5	2	
pH	2 + 13			



# BRAIDED PACKING



## STYLE 1048 PURE PTFE YARN

Pure PTFE yarn with corners reinforced with continuous aramid fibers, impregnated with colloidal PTFE and synthetic oil.

				Applications
T °C	-200 + +280			<ul style="list-style-type: none"> <li>Centrifugal and piston pumps, mixers, valves.</li> <li>Food, chemical and pharmaceutical industry</li> </ul>
P bar	25	300	500	
V m/sec	10	3	1	
pH	3 + 12			



## STYLE 1050 ORIGINAL PTFE-GRAPHITE

Expanded PTFE with pure graphite dispersion.

				Applications
T °C	-200 + +280			<ul style="list-style-type: none"> <li>Centrifugal pumps, reactors, mixers</li> <li>Valves, gates, taps, expansion joints</li> <li>Static seal on almost any chemical</li> </ul>
P bar	50	70	100	
V m/sec	25	5	2	
pH	0 + 14			



## STYLE 1051 HYBRID PTFE-GRAPHITE YARN

Expanded PTFE with graphite colloid dispersion.

				Applications
T °C	-120 + +250			<ul style="list-style-type: none"> <li>Worn shafts and pumps in poor conditions</li> <li>Centrifugal, plunger and piston pumps</li> <li>Valves and static applications</li> </ul>
P bar	40	60	80	
V m/sec	20	4	1	
pH	0 + 14			



## STYLE 1055 HYBRID PTFE-GRAPHITE YARN ON ARAMID

Aramid carrier wrapped with PTFE-graphite foil. High heat dissipation and tensile strength.



				Applications
T °C	-30 + +260			<ul style="list-style-type: none"> <li>High pressure applications</li> <li>Worn shafts</li> <li>High speed applications</li> </ul>
P bar	80	100	150	
V m/sec	15	4	2	
pH	0 + 14			





### STYLE 1066 GRAPHITE-ALUMINUM YARN



25% anti-friction metal foil and 75% expanded graphite, impregnated with corrosion inhibitor.

				Applications
T °C	-20 + +550			<ul style="list-style-type: none"> <li>• Slow to medium shaft speed applications</li> <li>• High temperature centrifugal pumps applications</li> <li>• Crude oil, tar, distillates and lower fractions, heat transfer fluids, hot oil</li> <li>• Sugar industry, crystallizers, paints</li> <li>• Shafts with hardness &gt; 500° brinell</li> </ul>
P bar	120	200	300	
V m/sec	10	3	1	
pH	3 + 11			



### STYLE 1077 PTK 28 YARN WITH PTFE



Texturized acrylic fiber, impregnated with 40% colloidal PTFE and synthetic oil.

				Applications
T °C	-25 + +200			<ul style="list-style-type: none"> <li>• General industry</li> <li>• Pulp &amp; Paper applications requiring non-staining white packings</li> </ul>
P bar	25	40	60	
V m/sec	15	3	1	
pH	3 + 12			



### STYLE 1077G PTK 28 YARN WITH GRAPHITE



Texturized acrylic fiber, impregnated with 30% colloidal graphite and synthetic oil. Higher heat dissipation than Style 1077.

				Applications
T °C	-25 + +200			<ul style="list-style-type: none"> <li>• General industry</li> </ul>
P bar	25	40	60	
V m/sec	15	3	1	
pH	3 + 12			



### STYLE 1080 ARAMID AND SYNTHETIC CARBON YARN

Interbraided pre-oxidized PAN and aramid fibers, impregnated with 30% colloidal PTFE and synthetic oil.

				Applications
T °C	-60 + +260			<ul style="list-style-type: none"> <li>• Slurries, polymerizing fluids, glue, pitches, abrasive fluids</li> </ul>
P bar	50	70	120	
V m/sec	30	10	3	
pH	1 + 13			



# BRAIDED PACKING



## STYLE 1099 COMBIGRAPH YARN

91% Expanded graphite wrapped around 9% synthetic graphite, impregnated with non-metallic corrosion inhibitor.



				Applications
T °C	-150 + +650			<ul style="list-style-type: none"> <li>• Heavy duty high temperature / high pressure pumps and valves</li> <li>• High speed applications</li> <li>• Abrasive and strong chemicals</li> </ul>
P bar	30*	80*	120*	
V m/sec	35	5	1	
pH	0 + 14			

\* with anti extrusion rings



## STYLE 1099R COMBIGRAPH YARN (REINFORCED)

93% Expanded graphite wrapped around 7% Inconel alloy wire, impregnated with non-metallic corrosion inhibitor

				Applications
T °C	-150 + +650			<ul style="list-style-type: none"> <li>• High temperature / high pressure pumps and valves</li> <li>• High speed applications</li> <li>• Abrasive and strong chemicals.</li> </ul>
P bar	-	-	300	
V m/sec	-	-	2	
pH	0 + 14			



## STYLE 1111 INCOGRAPH YARN



85% Expanded graphite wrapped around 15% Inconel alloy wire, impregnated with non-metallic corrosion inhibitor

				Applications
T °C	-150 + +650			<ul style="list-style-type: none"> <li>• Steam valves, sootblowers, gases</li> </ul>
P bar	-	-	300	
V m/sec	-	-	2	
pH	0 + 14			



## STYLE 1300 UNSINTERED PTFE

Pure unsintered PTFE yarn with special lubricants, its softness reduces shaft friction and allows a high degree of moldability. Available with addition of graphite dispersion (Style 1301).

				Applications
T °C	-58 + +500			<ul style="list-style-type: none"> <li>• Acids and alkalis, oils, gases, solvents, steam on centrifugal pumps, mixers and agitators.</li> </ul>
P bar	10	-	-	
V m/sec	10	-	-	
pH	0 + 14			



**S**EALTEK® Zero Leakage System® offers a variety of fibrous flexible compounds, replacing compression packing in the stuffing box.

This material evenly surrounds the shaft and works like a lubricated plug, eliminating pressure points. It ensures minimal friction, extended sleeve life due to no scoring and provides significant energy savings.

Zero Leakage System is available in various synthetic fibers, mixed with tixotropic and other lubricants. It is pressure treated to ensure uniform dispersion.

### BRAIDED PACKING OPERATIONAL COST

- 55% Product loss due to machine downtime
- 25% Value of leaked fluid
- 15% Labor cost
- 5% Packing purchase cost

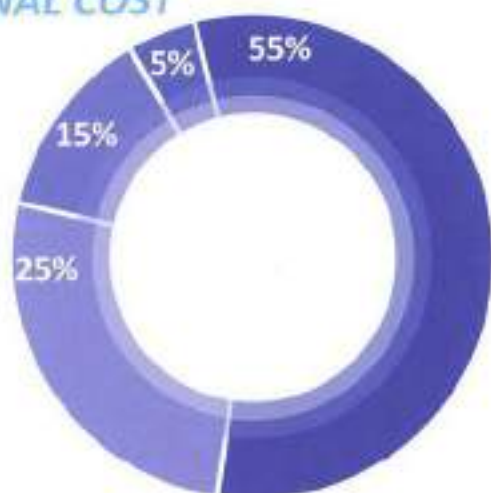

### PACKING OPERATIONAL COST WITH ZERO LEAKAGE SYSTEM

- 0% Product loss due to machine downtime
- 0% Value of leaked fluid
- 15% Labor cost
- 5% Packing purchase cost



# ZERO LEAKAGE SYSTEM



## BRAIDED PACKING

Leakage is necessary for lubrication.

- ✗ Optimal rate generally varies from 30 to 50 drops per minute, which can represent a yearly loss of more than 1200 lt (320 gal) of product.
- ✗ Packing require frequent replacements, causing machine shutdown and loss of production.
- ✗ Cooling made through lantern ring requires high water consumption. Packing compression reduces its effectiveness.
- ✗ To ensure prompt replacement, each packing size employed in a plant must have a large backup inventory. Demand peaks for a given size can cause downtime if not enough packing are on stock.
- ✗ Friction, especially with harder fibers that are needed for abrasive fluids, causes a very high absorption of power and a quick wear of the sleeve.

## ZERO LEAKAGE SYSTEM

- ✓ With a correct application, and under optimal mechanic conditions of the pump, leakage can be as low as Zero.
- ✓ After the first application, there is no replacement. Zero Leakage System is only refilled, without stopping the machine.
- ✓ No cooling or flushing is required.
- ✓ The same inventory can be used for stuffing boxes of ALL sizes and standards in the plant. Total inventory required for prompt replacement of all the plant's equipment is considerably lower. Stock control is easy, demand peaks are unlikely as ZLS is slowly refilled rather than replaced.
- ✓ While friction against the sleeve does take place, the self-lubricating fibers reduce it to only a fraction, if compared with braided packing.

### HOW IT WORKS:

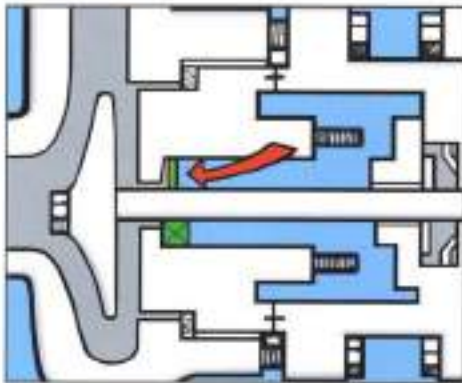

1 Install an anti-extrusion ring of braided packing or solid PTFE.

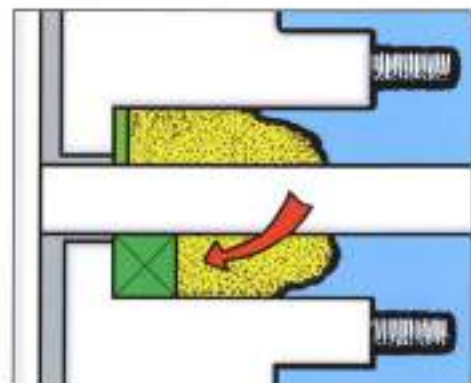

2 Hand fill stuffing box with compound, using gland follower to compact.

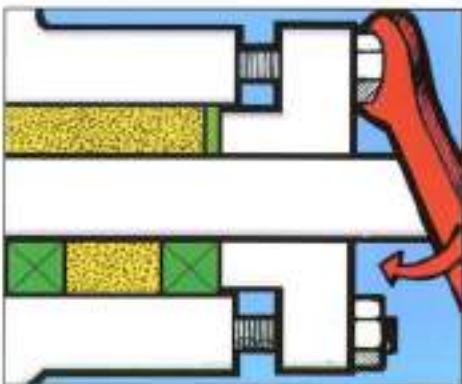

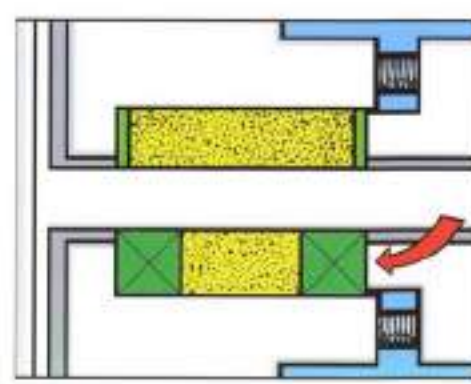

3 Install an anti-extrusion braided packing ring or a solid PTFE washer at gland side and "close" with stuffing box gland.



4 Tighten gland nuts to compress the compound and start up pump valve.

### STYLE ONE PTFE + graphite



Injectable packing compound made of expanded PTFE and graphite short fibres, mixed with tixotropic gel and special additives for heat dissipation. A revolutionary compression packing replacement, offering "zero leakage" conditions in many applications. Chemically inert, for easier plant standardization.

			
T °C	-80 + +280		
P bar	20	35	70
V m/sec	20	8	4
pH	0 + 14		
Vol	615 cm <sup>3</sup> /Kg		



### STYLE TWO Twaron® fibers

Injectable packing compound of 100% para-aramid, pure virgin Twaron® fibres mixed with clear tixotropic and PTFE lubricants. Will not stain or contaminate. Especially designed for use in paper mill applications, abrasive fluids, slurries and sewage water. No flushing is necessary, resulting in great savings in water and product.

			
T °C	-35 + +260		
P bar	25	40	80
V m/sec	18	4	2
pH	2 + 13		
Vol	830 cm <sup>3</sup> /Kg		



### STYLE FIVE PTFE fibers

Injectable packing compound made of virgin PTFE textured fibres and special inert lubricants for extremely high performances.

Meets FDA requirements. Ideal for packing pumps and valves in food plants, pharmaceutical and chemical industries and drinking water production.

No flushing is required, can be compressed close to "zero leakage".

			
T °C	-80 + +260		
P bar	20	30	60
V m/sec	8	3	1
pH	0 + 14		
Vol	640 cm <sup>3</sup> /Kg		





# ZERO LEAKAGE SYSTEM



## STYLE SEVEN Expanded Graphite

Injectable packing compound designed for heavy duty applications of high temperature and pressure, made of 100% expanded pure graphite. Suitable for steam valves, boiler feed and hot oil pumps, etc. No shaft or sleeve scoring. Highly recommended for use on old equipment in bad mechanical conditions.

			
T °C		-30 + +600	
P bar	40	70	90
V m/sec	25	5	2
pH		0 - 14	
Vol		710 cm <sup>3</sup> /Kg	



## STYLE TF350 Unbleached PTFE

Unique chemically resistant compound based on pure PTFE fibers and expanded PTFE pellets, mixed with special thixotropic lubricants. A great sealant achieving close to zero leakage conditions in packed pumps, valves and other devices with a peripheral speed of up to 8 m/sec. Recommended for use in cryogenic or high temperature applications. Seals almost all fluids including aggressive chemicals. *Does not stain.*



			
T °C		-40 + +260	
P bar	20	30	60
V m/sec	8	3	1
pH		0 - 14	
Vol		610 cm <sup>3</sup> /Kg	



## STYLE P99 G - P99GP Twaron® + Graphite

Pure virgin Twaron® fibers mixed with expanded mineral graphite flakes and special thixotropic heat resistant lubricants. This compound is designed for use in heavy duty pumps and valve applications, such as hot water, steam and diathermic oils, due to its excellent capacity for heat dissipation.

Available also as Style P99 GP, containing anti friction metal pellets, for specific use in applications with worn shafts or pumps in bad mechanical condition.

			
T °C		-20 + +300	
P bar	30	50	80
V m/sec	20	5	1
pH		1 - 13	
Vol		620 cm <sup>3</sup> /Kg	



### FLAT GASKETS GUIDELINES:

- Pressure and temperature limits are indicative and *should never be combined at their maximum values.*
- Surface compression should not exceed the maximum pressure of each individual material.
- Surface to be sealed must be free of pitting, flat, smooth, clean of dirt or old gaskets deposits.
- Parallel flanges are a necessary condition to avoid premature gasket failure.
- It is strongly recommended to use *torque wrench* when tightening.
- No anti-sticking agent should be applied when using **Sealtek®** gaskets.
- All **Sealtek®** gaskets are pre-treated with a nonstick agent and do not require any additional protection.



MAX TEMP.	550°C	550°C	550°C	550°C	280°C	250°C	300°C	280°C	260°C	260°C	260°C
STYLE	3000	3001	3002	3004	4005	4205	4400	5005	6000	6011	6050
AIR up to 95°C	○	○	○	○	○	○	○	○	○	○	○
HYDROGEN	○	○	○	○	/	/	/	●	○	○	○
NATURAL GAS	○	○	○	○	○	○	○	○	○	○	○
LOW PRESSURE STEAM	○	○	○	○	●	●	○	/	○	●	●
SATURATED STEAM	○	○	○	○	/	/	●	/	/	/	/
SUPERHEATED STEAM	○	○	○	○	/	/	/	/	/	/	/
DIATHERMIC OIL	○	○	○	○	●	/	○	/	○	●	●
WATER	○	○	○	○	○	○	○	○	○	○	○
SUPERHEATED WATER	○	○	○	○	○	○	○	○	○	○	○
AMMONIA	○	○	○	○	○	○	○	○	○	○	○
MILD ALKALIS	○	○	○	●	○	○	○	○	○	○	○
STRONG ALKALIS	○	○	○	○	○	○	○	○	○	○	○
MILD ACIDS	○	○	○	●	○	○	○	○	○	○	○
STRONG ACIDS	●	○	●	●	○	○	○	○	○	○	○
PETROLEUM SOLVENTS	○	○	○	○	○	○	○	○	○	○	○
NON AROMATIC SOLVENTS	○	○	○	○	○	○	○	/	○	○	○
CHLORINATED SOLVENTS	○	○	○	○	/	/	/	/	○	○	○
PAINTS	○	○	○	○	/	/	●	●	○	○	○
KETONES	○	○	○	○	/	/	/	/	○	○	○
FUELS	○	○	○	○	○	○	○	●	○	○	○
FREON	○	○	○	○	○	○	○	○	○	○	○
HYDRAULIC OILS	○	○	○	○	●	●	○	●	○	○	○
NUCLEAR POWER PLANTS	/	○	/	/	/	/	/	/	○	○	○
PER F.D.A. REQUIREMENTS	/	○	/	/	○	○	/	/	○	○	○

○ Suggested ● To be prudently evaluated / Not suitable For other applications, please consult factory

# FLAT GASKETS

## STYLE 3000

Gasketing sheet in **pure expanded graphite** reinforced with **AISI 316 steel multiple layers**. Does not contain binders. Can virtually be used on all applications, even the heaviest ones. Withstands **extreme temperatures**, does not stick and is not affected by aging or hardening. Particularly suitable for low surface pressure flanges and heavy duties.

### Technical data

Max. Pressure	130 bar
Max. Temperature	550°C
P × T Factor	max 30.000
Color	Black



## STYLE 3001

Gasketing sheet in **expanded pure mineral graphite** reinforced with **tanged AISI 316 foils** with no binder. Can be used in all applications, even the heaviest ones. High pressure and temperature resistant, does not stick and is not affected by ageing or hardening. Thermal shock resistant, **no hot/cold flow**, high recovery, with inorganic corrosion inhibitor and scratch-proof surface treatment.

### Technical data

Max. Pressure	130 bar
Max. Temperature	550°C
P × T Factor	max 40.000
Color	Black



## STYLE 3002

Gasketing sheet in **expanded pure mineral graphite**, reinforced with a **AISI 316 steel net**. Does not contain binders. It can be virtually used on all applications, including the heaviest ones. Extreme temperature resistant. Does not stick and is not affected by ageing. Particularly suitable in flanges with low surface pressure and heavy duty applications. **Ideal for cut gaskets production** due to its ease of cutting.

### Technical data

Max. Pressure	130 bar
Max. Temperature	550°C
P × T Factor	max 30.000
Color	Black



## STYLE 3004

Gasketing sheet in pure graphite, in **sandwich structure**, made of expanded pure graphite central core, **lined on both sides by aluminum foil**. It represents the ultimate recent innovation in the gaskets field, eliminating problems related to the use of pure graphite. **Easily handled and cut**.

### Technical data

Max. Pressure	80 bar
Max. Temperature	550°C
P × T Factor	max 24.000
Color	Silver





### STYLE 4005

Asbestos free gasketing sheet, made of **aramid fibers**, **Rockwool fibers**, and **elastomeric NBR binders**. Manufactured as standard material for a wide range of applications in all industries. Excellent tensile strength, elastic and resilient, does not stick to gland surface. Very competitively priced.

#### Technical data

Max. Pressure	100 bar
Max. Temperature	300°C
P × T Factor	21.000
Color	Green

### STYLE 4205

Compressed sheet material made of aramid fiber with NBR rubber and **special inorganic fillers**. Due to its high-aramid fibers content, it achieves **excellent thermal values** and the material features a very good adaptability for coping with unevenness in flange surfaces. The combination of aramid fibers and physiologically neutral binding agents ensures the mechanical strength of the material. This makes the sheet flexible and very easy to handle.

#### Technical data

Max. Pressure	100 bar
Max. Temperature	300°C
P × T Factor	21.000
Color	Blue

### STYLE 4400 XP

Gasketing sheet manufactured with an innovative system which **reinforces pure compressed graphite** with **aramid fibers** and a very low quantity of elastomeric binder. The high flexibility, the mechanical strength and the perfect resiliency eliminate any need for other reinforcements. Easy to handle and cut. Suitable for the heaviest applications. Available with **steel net reinforcement** (Style 4800).

#### Technical data

Max. Pressure	105 bar
Max. Temperature	350°C
P × T Factor	max 25.000
Color	Gray-black

### STYLE 5005

Asbestos free gasketing sheet, made of **aramid fibers**, **insert mineral fibers**, PTFE and chemically high resistance synthetic binders. Combines **excellent resistance to chemical products** with good compressibility and recovery. Does not stick to surfaces thanks to Sealtek's surface anti-sticking agent.

#### Technical data

Max. Pressure	50 bar
Max. Temperature	200°C
P × T Factor	max 6.000
Color	Ivory



# FLAT GASKETS

## STYLE 6000

Style 6000 is a gasketing material containing **inorganic round beads** consistently spread over a **modified PTFE base**. This unique mixture allows for precision control over cold-flow problems inherent with virgin PTFE. The special mixture of Style 6000 virtually **eliminates the need for retightening** and is the result of over a decade of research, development and testing.

### Technical data

Max. Pressure	250 bar
Max. Temperature	260°C
P × T Factor	max 20.000
Color	White



## STYLE 6011

Gasket made of **biaxial silica-loaded pure PTFE**, suitable for a wide range of applications requiring the best possible mechanical strength. Can work on strong acids (except hydrofluoric), alkalis, solvents, hydrocarbons, chlorine, steam, oils, water, sewage. **Extremely low permeability to gases**, high resistance to **creep and cold-flow** if compared with traditional and modified PTFE and easy cutting properties.

### Technical data

Max. Pressure	85 bar
Max. Temperature	260°C
P × T Factor	max 14.000
Color	Orange



## STYLE 6050

High performances gasketing sheet made of **biaxial pure PTFE** loaded with **barium sulphate** and special inorganic micro-beads. Works on strong acids, alkalis, solvents, hydrocarbons, chlorine, steam, oils, water, fluorine and hydrofluoric acid. The chemical resistance is well combined with extremely **low permeability to gases**, high resistance to **creep and cold-flow** if compared with traditional PTFE.

### Technical data

Max. Pressure	85 bar
Max. Temperature	260°C
P × T Factor	max 16.000
Color	Sky-blue



## STYLE 8001 ULTRATHERM

Style 8001 Ultratherm is an innovative gasketing material completely **free of any rubber binding material**, graphite and synthetic fibers made of **pure laminated mica-phlogopite** and reinforced with tanged AISI 316 steel. Perfectly resistant to scratches and bad handling. Offers great advantages on high temperature flanges of heat-exchangers, gas turbines, gas turbine housing, high temperature piping on power plants, steel mills and other critical applications.

### Technical data

Max. Pressure	150 bar
Max. Temperature	950°C/1100°C
P × T Factor	55.000
Color	Light Brown





*MAINTENANCE AND REPAIR PRODUCTS*





	Page n.
Maintenance and repair products	
Seal-Tex	45
Online pipeline repair and protection tapes	46
Industrial Maintenance Chemicals	47
Special products	48
Lubricants	50
Coatings	52
Cleaners	54
Ultra Metal System	57



Sealtek® SEAL-TEX is a **FAST-CURING TAPE** ABLE TO REPAIR ANY PIPING:

- in 20 minutes
- with the work of only one man
- with minimal costs
- without emptying the line.

With only a small impregnation with water, used as a catalyzer, the fast-curing tape can reach a hardness of 80 shore A after 10-15 minutes of contact with moisture. It can be applied to pipes that are leaking or have corroded surfaces.

Sealtek® SEAL-TEX fast-curing tape can withstand contact with a very wide range of fluids, such as crude oil, sulfuric acid (>10%), caustic soda, steam and many others.

SEAL-TEX is officially **certified and approved** according to **ASME PCC-2/2008** for repair of pressure equipment and piping.



#### Technical data

Pipe pressure without GF-HD	30 bar
Pipe pressure with GF-HD	50 bar
Flexural strength	ASTDM D709 111 N/mmsq
Tensile strength	ASTDM D638 172 N/mmsq
Compression strength	ASTDM D695 180 N/mmsq
Adhesion at one-inch single overlap	19 N/mmsq
Dielectric strength	16 KV/mm
Continuous temperature resistance	120°C - "XT" version up to 500°C
Peak temperature resistance	190°C - "XT" version up to 550°C
Chemical resistance	Water, salt water, oil, diluted acids, and alkalis.
Shelf life	@20°C: 3 years



### SEAL TEX XT high temperature curing tape

Continuous temperature resistance: up to 500°C

Peak temperature resistance: up to 550°C

# ONLINE PIPELINE REPAIR

## SELF SEAL SELF-POLYMERIZING TAPE

Sealtek® SELF-SEAL is a self-polymerizing tape made of siliconic rubber, suitable for immediate application before Sealtek® SEAL-TEX being used. Wrapping the tape around the leaking pipe will allow an easier and quicker repair operation, thanks to its self-conglomerating properties. To seal large holes, a wooden wedge or a screw can be employed, together with Sealtek® SELF-SEAL.

### Technical data

Color	Blue
Resistant to	Oils, water, ozone, most chemicals
Max Temperature	260°C
Applications	Temporary leakage dampening for Seal-TEX ease of application; Low pressure sealing; Tools electric insulation



## FLANGE-SEAL FLANGE COVER

Sealtek® FLANGE-SEAL is a revolutionary system able to replace flange shields in a very wide range of applications, removing the need of large stocks of different sized covers to match different sized flanges.

### Technical data

Color	Gray
Resistant to	Oils, water, ozone, most chemicals
Max Temperature	260°C
Applications	Prevention of harmful spray-outs and mist formation from failing pipe joints



## GF - HD FIBERGLASS PUTTY (HIGH DENSITY)

GF-HD is a pre-dosed polymeric molecular compound made of fiberglass grains and a catalyst which is inside the molecular matrix. The amount of product required for the repair can be cut off the stick and kneaded between fingers until the two parts are completely mixed, before applying on the area to be repaired. The mix will cure and harden in a few minutes. Recommended for repairing or rebuilding all synthetic parts with few exceptions. Can also be used for the repair of metal parts underwater and wet environments where normal polymers would not react.

### Technical data

Pot life at 20°C	20 minutes
Specific weight	2,45 g/cm³
Polymerization time	min 1 hour - max 24 hours
Working temperature	-35°C + +120°C



## LEAK-3 ONLINE SEALING PASTE

Sealtek® LEAK-3 Online Sealing Paste is a revolutionary compound able to immediately dampen or completely seal a leakage with as little as a gesture.

### Technical data

Color	Dark amber
Resistant to	Water, hydrocarbons
Max Temperature	70°C
Applications	Low pressure leakage sealing; Surfaces waterproofing



## INDUSTRIAL MAINTENANCE CHEMICALS *overview*

It's not about how much a lubricant or a cleaner costs.  
It's about how much you'll spend yearly in lubricants or cleaners  
in the end to achieve the same result.

The world of chemical products for industrial applications is seemingly endless. The range spans through different combinations of efficiency, cost-effectiveness, environmental impact and safety for operators. **Sealtek®** has always promoted a culture of *productive maintenance* through hi-tech chemical products aimed at achieving the highest degree of effectiveness while never neglecting their impact on operators and the environment.

What makes **Sealtek®** stand out in the market is its wide range of products which can drastically *decrease maintenance costs in everyday plant operations* while at the same time *improve the working conditions for the people involved*. The philosophy behind our products' formulation is: the better our product is, the fewer applications will be required to achieve your goal. Fewer applications means less product being used, less pollution, less waste, less work.

**Sealtek®** has *focused on environmentally friendly alternatives* ever since its inception, decades ago, when environmental regulations were still very loose. With laws becoming increasingly stringent, the need to optimize maintenance costs is critical to offset decreasing margins in several markets. Employing clean and cost-effective maintenance products is the best way to create considerable value while reducing the global environmental impact of operations.



# SPECIAL PRODUCTS



## CUTTING OIL

Fluid with high lubricating - cooling capacity to facilitate cutting, drilling, tapping and machining in general of all ferrous and non-ferrous metals. Adheres to tool surface. No vapors.

Product Characteristics	Applications
<b>Integral lubricant</b>	
<b>Cooling agent</b>	
<b>All-purpose</b>	<ul style="list-style-type: none"><li>• Cutting, lapping, machining of all metals</li></ul>
<b>Does not run or dip</b>	
<b>With EP additives</b>	
<b>No corrosion where applied</b>	



## LEAKS DETECTOR

New polymeric fluid for fast and safe detection of any leakage from pipes, flanges, gaskets and joints of any size. Suitable for oxygen, compressed air and all gases.

Product Characteristics	Applications
<b>For all fluids</b>	
<b>Non flammable</b>	<ul style="list-style-type: none"><li>• Detection of leakage of liquid and gases from any kind of piping.</li></ul>
<b>Leakage immediately detected</b>	
<b>Non pollutant</b>	
<b>Easy to use</b>	



## METAL-FREE ANTI-SEIZE COMPOUND

Suspension of non-metallic microparticles featuring a high surface strength plus special EP additives able to withstand temperatures of up to 1800°C (3270°F), high pressures, strong chemicals and moisture.

Product Characteristics	Applications
<b>Fully synthetic</b>	
<b>100% metal free</b>	<ul style="list-style-type: none"><li>• Prevents self-welding, corrosion and seizing of bolts and nuts in all environments</li></ul>
<b>For all metals</b>	
<b>Protects from corrosion</b>	
<b>Sealant</b>	
<b>No pitting</b>	



## METAL-FREE ANTI-SEIZE COMPOUND F.G.

Special food-grade certified lubricant with non-metallic particles able to withstand high temperatures, high pressures and chemical agents.

Product Characteristics	Applications
<b>100% metal free</b>	
<b>For all metals</b>	<ul style="list-style-type: none"><li>• Prevents self-welding and seizing of bolts, nuts and metal-to-metal bonding in food plants.</li></ul>
<b>Protects from corrosion</b>	
<b>Does not carbonize</b>	
<b>Efficient up to 1450°C</b>	
<b>Meets FDA requirements</b>	





### METAL PLUS

Special anti-seize and lubricant compound containing pure foliated copper microbeads, corrosion inhibitors and EP Additives.

Product Characteristics	Applications
Pure foliated copper	
Up to 1100°C	
Anti-seize	<ul style="list-style-type: none"> <li>Lubricant for extreme temperature</li> <li>Prevents seizing of soft metals.</li> </ul>
Lubricant for extreme temperatures	
Protective coating	
No dangerous nickel or other toxic components	



### MOLD RELEASE AGENT

A high concentration silicone compound to facilitate release during molding of plastics, rubber and other synthetic materials. Keeps waste to a minimum, improves surface finish and reduces duration of production.

Product Characteristics	Applications
Higher number of releases	
Protects steel molds	
Improved finish	<ul style="list-style-type: none"> <li>Rubber and plastic injection, hot press molding.</li> </ul>
Less waste	
Increases production	
High active agent concentration	



### ULTRACUT

Totally synthetic fluid for cutting, drilling, and tapping of ferrous metals, stainless steel and alloys. Completely free of toxic solvents, environmentally friendly and releasing no noxious vapors. Biodegradable and safe. Highly efficient and reliable.

Product Characteristics	Applications
Not dangerous	
Very effective	
Not flammable	<ul style="list-style-type: none"> <li>Cutting, machining and turning of all kinds of metals.</li> </ul>
No smokes	
For all metals	
Safe for workers	



### ULTRAGRIP

Prevents driving belts of any form or material from slipping. Keeps tension constant, protects against cracking and hardening, does not stain or form any deposit or lump.

Product Characteristics	Applications
Prevents slipping	
Increases traction capacity	
Keeps tension constant	<ul style="list-style-type: none"> <li>Increasing and keeping driving belts' grip, protection of driving belts.</li> </ul>
Protects against ageing	
Water-repellent	
For all belt types	



# LUBRICANTS



## ULTRASOL

Penetrating fluid with a high solvent and loosening capability. Quickly frees rusted and oxidized nuts, bolts and other mechanical parts. Leaves a protective film after treatment.

### Product Characteristics

- Fast loosening power
- Penetrates in depth
- High speed action
- Acid-free
- Protective and corrosion-proof
- Food-grade version available

### Applications

- Rust solvent to loosen bolts, nuts and other blocked metal parts



## DETERGENT AND LUBRICATING OIL

Light, pure, semi-synthetic oily compound penetrating the smallest tolerances, clearing and coating surfaces with a lubricating and protective film.

### Product Characteristics

- Low surface tension
- Penetrates the smallest tolerances
- Cleansing action
- Excellent lubricant
- Contains EP additives
- Inhibits corrosion

### Applications

- Multi-purpose fluid for all industrial light and clean lubrication.



## DRIVING CHAIN LUBRICANT

Deeply penetrates and lubricates pins and bushings of any size on driving chains, even if taken to extreme loads. Inhibits corrosion, protects against moisture, makes running smoother. Also ideal for greasing metal ropes.

### Product Characteristics

- Low surface tension
- Does not thicken
- Protects against corrosion
- Prolonged action in time
- Contains EP additives
- Two-steps treatment

### Applications

- Lubrication of all kinds of driving chains.



## H.T. LUBRICANT GREASE

Polyvalent lubricant grease for high temperatures. Effectively resistant to oxidation, heavy loads, high and low speeds. No drop point. Contains corrosion inhibitors.

### Product Characteristics

- Extreme load resistant
- Effective from -25°C to 220°C
- Contains EP additives
- Oxidation proof
- Stabilized against corrosion
- Inhibits corrosion

### Applications

- Lubricant grease for high temperature applications



### H.T. MOLY SYNTHETIC LUBRICANT

Totally synthetic, leaves no carbon residue or ash. Lubricates at extremely high temperatures (840°F) thanks to its content of molybdenum disulphide. High pressure resistant, Powerful cleansing action.

#### Product Characteristics

Contains molybdenum disulphide

Efficient at -35C ÷ +450°C

Leaves no residual matter

Performs a cleansing action

Contains EP additives

#### Applications

- Extreme temperature lubrication; dry lubrication even at highest temperatures.



### MOLY PLUS

Lubricant, protective and anti-seize compound based on molybdenum disulphide, containing special EP additives and synthetic polymers. Makes assembling and dismantling of machinery parts easier, lubricates and provides long lasting protection.

#### Product Characteristics

100% metal-free

Up to +450°C

In compliance with MIL-M-7868 A-B

Highly lubricating power

Anti-seize

Protective

#### Applications

- All metal-to-metal connections.
- Avoids seizing and corrosion



### PTFE COATING

Dry, clean, pure PTFE coating. Adheres strongly to the substrate. Minimizes friction on any porous and non-porous surface. Resistant to water and strong chemicals. Easy to apply.

#### Product Characteristics

Abrasion proof

Minimizes friction

Clean and dry

For all surfaces

Excellent releasing agent

#### Applications

- Dry and clean release agent
- Improving friction properties in hoppers, chutes and sliding surfaces



### PTFE WHITE GREASE COMPOUND

A mixture of extra-pure refined mineral grease, non-toxic synthetic greases and micronized PTFE. Resistant to water, steam and acid vapor. Does not harden or drip.

#### Product Characteristics

100% non toxic

Does not harden

Semi-synthetic

High temperature resistant

Odorless and tasteless

Does not stain

#### Applications

- For the accurate lubrication of moving parts in the food, pharmaceutical and textile industries.



# LUBRICANTS + COATINGS



## SILICONE LUBRICANT

Highly concentrate silicone fluid. Water-proofing and releasing agent. Does not stain or dirt. Works efficiently at extreme temperatures.

### Product Characteristics

High percentage of pure silicone

Lubricates and protects

Waterproof and water repellent

Excellent releasing agent

Non-toxic and safe

Effective from  $-40^{\circ}\text{C}$  to  $+220^{\circ}\text{C}$

### Applications

- Lubrication of plastic, rubber and sundry synthetic parts.

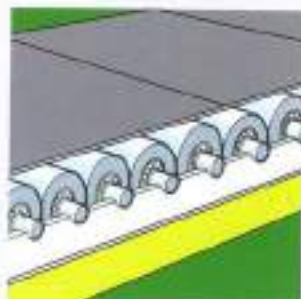

## SYNTHETIC LUBRICANT

Completely synthetic oil. Leaves no carbon or ash deposit. Lubricates at extremely high temperatures and in heavy conditions. Resistant to extreme pressure. Powerful cleansing action.

### Product Characteristics

Contains synthetic EP additives

Effective  $-35^{\circ}\text{C}$  +  $+250^{\circ}\text{C}$

Cleansing action

No residual matter left

Universal

Cost-effective

### Applications

- Lubrication at high temperatures and high pressures, when required in large volume.



## ULTRAFLEX

Surface lubricant for chain drives, wide rope and gears. Long lasting lubrication and protection with enhanced adhesive properties and EP additives. Moisture resistant, reduces noise.

### Product Characteristics

Fluid lubricant with EP additives

Adhesive

Anti-corrosive protection

Water repellent

Resistant to chemical vapors

Easy to apply

### Applications

- Lubrication of chain drives, wide ropes and gears.
- Especially suitable for lubricating railroad switches plates.



## COLD GALVANIZING COMPOUND

Quick and safe galvanizing of ferrous metals. No chalking or scaling. Long term resilience. Available in two versions. Easy to apply.

### Product Characteristics

Electrochemical galvanizing

Excellent base

Ideal for touching-up

Prevents galvanic corrosion

Temperature resistance up to  $120^{\circ}\text{C}$

Flexible

### Applications

- Long term galvanic coating for all ferrous metals.

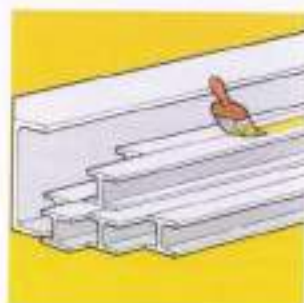

### HEAVY DUTY RUST GUARD

Protects against corrosion, rust and oxidation without having to paint. Forms an elastic, waterproof and self-sealing film that needs no particular surface treatment prior to application.

#### Product Characteristics

Medium term protection: 2 years and more

Easy to apply and remove

No specific surface treatment required

Waxy consistency

Clear and amber color

Complies with MIL C-16173D specs

#### Applications

- Coating and protection of metal parts subject to rust and oxidation.



### MOISTURE SHIELD

Creates a semi-oily, extra-thin film. Removes moisture, prevents the formation of rust and corrosion, penetrates the smallest recesses. Easy to remove.

#### Product Characteristics

Low surface stress

Penetrates and lubricates

Short-term anti-corrosive

High dielectric strength

Complies with mil. C-16173D specs. Level 3

Easy to remove if necessary

#### Applications

- Coating and protection of surfaces against moisture.



### RUST TRANSFORMER

Able to turn iron oxide (rust) into inert salt through an electrochemical process. Creates an ideal base for adhesion of the undercoat, eliminating the need to employ costly and dangerous methods such as sandblasting, scraping and treatment with strong acids.

#### Product Characteristics

Transforms rust in an inert substance

Extremely large covering capacity

No need to rinse

Easy to apply

Does not contaminate the atmosphere

#### Applications

- Quick and easy treatment of rusty and oxidized metal parts



### ULTRASTEEL

Protective coating made of pure stainless steel colloid, creating a layer with high chemical, mechanical and heat resistance over all types of metals and other materials. Avoids corrosion and scaling in all aggressive environments.

#### Product Characteristics

Long term protection

Temperatures up to 500°C

No chalking or flaking

Chemicals resistant

Easy to apply

Can be applied everywhere

#### Applications

- Long term protection against corrosion and scaling in aggressive and high temperature applications.



# CLEANERS



## CARBON AND VARNISH SOLVENT REMOVER

High decarbonizing action solvent. Resolves carbon links. Solubilizes sludge, pitch, old stubborn paint. Phenol-free. No bad odors. Can be diluted and has a low evaporation rate. Nonflammable.

### Product Characteristics

### Applications

Phenol-free

Non-corrosive

Very slow evaporation

Can be diluted

Cost-effective

- Removal of combustion deposits, greasy substances and carbon sludge stuck inside engines, carburetors, valves and electric motors casings.



## ELECTRIC CONTACT CLEANER

Quick evaporation synthetic detergent for cleaning electric and electronic equipment. High purity, leaves no trace, non-flammable. Harmless and non-toxic.

### Product Characteristics

### Applications

Generating no flame

Optimum dielectric resistance

Leaves no residue

Fast evaporation

Effective and penetrating

- Removal of grease, dirt and dust from electric and electronic equipment



## ELECTRIC MOTORS CLEANER

Degreasing agent with high dielectric resistance for cleaning electric motors and other equipment. Non-conductive and non-corrosive. Leaves no greasy residue and contains no carbon tetrachloride or other toxic substances. Almost odor-free.

### Product Characteristics

### Applications

Low conductivity

Inexpensive

Safe for user

Fast cleaning action

High flash point

Environment friendly

- Cleaning and degreasing of electric motors, generators, air conditioners, fans, transformers and tools.



## INDUSTRIAL AND NAVAL SOLVENT

Highly concentrated alkaline detergent. Effective on most inorganic dirt. Toxic solvent free. Non-flammable. Slight anticorrosion effect. Low-foaming, suitable for marine industry.

### Product Characteristics

### Applications

Extremely versatile

Toxic solvent free

Antirust action

Non-corrosive

Quick cleansing action

Very cost-effective

- Fast and effective cleaning of industrial machinery, factory floor, pumps, ducts, ships bilges, superstructures



### INDUSTRIAL DETERGENT DEGREASER

Solvent cleaner for thick dirty deposits, quickly dissolving and removing sludge, tar and grease. Completely odorless. High flash point (higher than 80°C / 176°F). Low evaporation coefficient.

#### Product Characteristics

- Quick working
- Completely odorless
- Slow evaporation
- Does not pollute
- High flash point
- Cost-effective

#### Applications

- Maintenance and cleaning of all machinery and equipment in the industrial and marine sector.



### MULTI PURPOSE CLEANER

Detergent and degreaser fluid for metal parts. Quickly dispatches even the thickest grease and sludge without corroding metal. Leaves a thin protective film afterwards. Very cost-effective and user-friendly, environmentally safe.

#### Product Characteristics

- Non-pollutant
- Very effective
- Low volatility
- No corrosion induced
- High flash point
- Environmentally friendly

#### Applications

- Low cost versatile solvent to replace chlorinated hydrocarbons.



### PHOSPHATE-FREE DETERGENT CLEANER

Highly concentrated alkaline detergent specifically for cleaning even the most stubborn organic dirt: contains no polluting phosphates, toxic solvents or dangerous ingredients. Biodegradable and versatile.

#### Product Characteristics

- Biodegradable
- Concentrated
- Effective on organic dirt
- Versatile
- Solvent-free
- Cost-effective

#### Applications

- Safe and environmental-friendly cleaner for organic dirt in civil (hospitals, schools, restaurants, supermarkets) and industrial (food, livestock, marine) sector.



### SAFETY CLEANER AND SOLVENT

Quick degreaser and detergent for electrical and mechanical equipment. Contains corrosion inhibitors. Fast evaporation, high dielectric force. Leaves no deposit.

#### Product Characteristics

- High flash point
- Fast evaporation
- High TLV
- Stabilized
- Non-corrosive
- High dielectric resistance

#### Applications

- Cleaning of electrical equipment, motors, switches, relays. Replacement of oil-based products for cold and thorough cleaning of mechanical equipment.



# CLEANERS



## **SUPER RUST REMOVER** with corrosion inhibitor

Fast rust, corrosion and scale dissolving agent. Removes deeply imbedded oxidation from all ferrous metal, temporarily granting them protection against corrosion. Also effective against organic and inorganic dirt.

### Product Characteristics

Removes rust

Gives temporary protection

Effective cleansing action

Does not corrode metals

Diluted with water

Cost-effective

### Applications

- Rust removal from ferrous materials such as copper, aluminum, brass and bronze; preparation of surfaces for paint or plating.



## **ULTRACLEAN TYPE C - TYPE D**

Detergent, degreasing and deodorizing fluid suitable for all cleaning operations of industrial and civil activity. Vegetal base, pleasantly orange-scented, totally biodegradable, made of natural and eco-compatible substances but extremely effective and powerful.

### Product Characteristics

Vegetal base.

Detergent and degreaser

100% biodegradable

No foam

Safe for workers and environment

Phosphate free

### Applications

- Safe and environmentally friendly cleaner to remove dirt, grease, oil and wax in all industrial applications.





Highly advanced metal or ceramic compounds, developed for the **repair, reconstruction or protection of equipment or metal parts, damaged by corrosion, erosion, chemical attack or abrasion.**

Manufactured with a two components modified epichlorohydrin epoxy resin, incorporating metallic, mineral and ceramic fillers, UMS provides easy, fast, reliable and impressive results in all maintenance applications.

Damaged metal surfaces can be fully repaired or reconstructed, the repaired part achieving an even better resistance with **merely one coat of polymeric compound**, which due to its insulating capability **eliminates possible future corrosion or pitting.**



# ULTRA METAL SYSTEM



## PHYSICAL PROPERTIES

TYPE	COMPOSITION	COLOR AFTER CURING	MIXING RATIO				POT LIFE AT 20°C (min.)	SPECIFIC WEIGHT OF MIXT. g/cm <sup>3</sup>	TEMPERATURE RESISTANCE FROM/TO	CURING TIMES (in hours)	
			% weight		% volume					handling strength	final hardness
			resin	hardener	resin	hardener					
AL-P	80% aluminum - 20% resin	Aluminum	100	20	4.5	1	80	1.6	-35°C; +120°C	16	24
AL-L	80% aluminum - 20% resin	Aluminum	100	14	4	1	60	1.45	-33°C; +120°C	16	24
TI-P	80% titanium - 20% resin	Grey	100	33	-	-	110	1.61	-35°C; +200°C briefly +260°C	-	48
ST-HT	80% steel/putty - 20% resin	Dark grey	100	100	1	1.1	30	2.34	-35°C; +200°C briefly +280°C	12	20
FAST	80% steel - 20% resin	Dark grey	100	13	2.5	1	5	1.6	-35°C; +90°C	3	6
FLEX-Y	100% polyurethane resin	Colorless	-	-	-	-	depend on mixture min. 30'	0.97	-35°C; +55°C	Depending on mixing ratio.	
CE-WRW	80% zirconium oxide - 20% resin	White	100	33	-	-	120	1.59	-35°C; +200°C briefly +260°C	-	48
CE-P	80% ceramic/steel - 20% resin	Dark grey	100	21	1.9	1	45	1.67	-35°C; +120°C	16	24
CE-L	80% ceramic/steel - 20% resin	Black	100	15	2.8	1	45	2.1	-35°C; +120°C	18	24
CE-SR	80% ceramic/steel - 20% resin	Blue	100	15	3.5	1	40	1.8	-35°C; +180°C	16	24
ST-P	80% steel - 20% resin	Dark grey	100	10	4	1	60	2.9	-35°C; +120°C	16	24
ST-L	80% steel - 20% resin	Dark grey	100	7	4	1	60	2.75	-35°C; +120°C	16	24
ST-HD	50% steel - 50% resin	Dark grey	-	-	-	-	5-10	-	-35°C; +120°C	0.5	24

**AL-P ALUMINUM PUTTY**

Aluminum putty compound for repair, rebuilding and protection of aluminum and light alloy parts. Manufactured with extra-fine aluminum powder to ensure perfect and homogeneous dispersion and a special resin, based on epichlorohydrin epoxy Pm  $\leq 700$ . For filling blowholes, for repairing and restoring injection molded parts and holding devices, for sealing and glueing.

**AL-L LIQUID ALUMINUM**

Aluminum compound in liquid form used in repairing and protecting aluminum and light alloy parts. Designed and recommended for making models, forms, frames, prototypes and holding devices. Used for coating special light alloy tools, holding devices in ultrasonic welding machines and for precision testing. Manufactured with extra-fine aluminum powder mixed with a special resin, penetrates into the smallest tolerances and metal pores, becoming part of the base material after curing.

**TI-P/TIW-P TITANIUM PUTTY**

Recommended for the repair and reconstruction of metal surfaces. Made of titanium fillers and advanced link agents, Ti-P is the ideal compound when high compressive strength and chemical resistance is required. Recommended when repairing pump casings, bearings and bearing housings, driving key seats, shafts, sleeves, etc. Can be used also as a complete anticorrosion coating on metal components and can be easily applied on vertical surfaces.

**ST-HT STEEL PUTTY High Temperature**

Special steel-based putty compound, featuring an extra high temperature resistant resin. Particularly suitable for plant maintenance and the repair or rebuilding of pumps, valves, pipes, etc. operating in high temperatures. Often used to produce blanking and forms, repair prototypes or filling blow holes. Operates in applications at 200°C continuous and 280°C peak temperature.





## **FAST** FAST CURING STEEL

Steel-filled compound for quick repair of metal surfaces. Its extremely short curing time allows it to be used where speed is required in maintenance or repairs of leaking pipes, engine casings, gear boxes. Due to its fast curing feature, it displays a lower physical and chemical resistance and should be coated and reinforced after curing with other SEALTEK® metal compounds.



## **FLEX-Y** RUBBER-LIKE ADDITIVE

Special polyurethane hardener, recommended for use in conjunction with CE-P, CE-L and ST-P compounds. Will convert the usually very hard compounds into a "rubber-like" state, which can vary in consistency according to the amount added. Ideal for creating slick absorbing surfaces where their continuous impact with large size particles may damage, scratch or score them.



## **CHEM-L** CHEMICAL RESISTANT COATING Liquid

Two component polymeric compound made of epoxy resins filled with silicates and stabilized with silicones.

Suitable for resurfacing, protecting or repairing iron, cement and concrete surfaces such as in pump casings, tanks and industrial floors. Can be applied and will adhere onto wet or humid surfaces at low temperatures. Offers an extremely wear and chemically resistant surface which will also resist abrasion and pressure shocks as well as chemical attack.

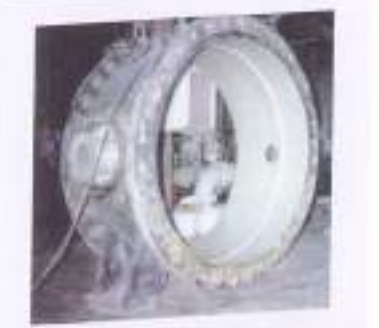

## **CE-WRW** ABRASION SUPER-RESISTANT PUTTY CERAMIC

Special ceramic polymeric putty made of pure alumina and titanium dioxide, recommended for the protection of metal surfaces against heavy abrasion and erosion. The CE-WRW high viscosity makes it ideal for use on vertical or overhead applications as it will adhere to the treated surface and will not drip. Its white color makes it ideal for coating sensitive areas where a darker coating may present staining problems.



**CE-P METAL CERAMIC PUTTY**

Ceramic steel putty compound for the repair and rebuild of all metal parts subject to erosion, corrosion or abrasion attack, as well as to create wear-resistant surfaces. When correctly mixed with the specific Flex-Y polyurethane hardener, it will provide a flexible surface, able to absorb shocks and vibrations and offer outstanding performance and results.

**CE-L LIQUID METAL CERAMIC**

Liquid ceramic steel compound used for the repair or protection of all metal surfaces subjected to strong erosion, corrosion and abrasion. Formulated with an extremely chemical resistant resin, can be used in rebuilding damaged parts or to create a wear resistant surface. When correctly mixed with the special Flex-Y polyurethane hardener, produces a flexible surface which outperforms the original material itself. Easily applied by brush, roller or trowel.

**CE-SR ABRASION SUPER-RESISTANT LIQUID CERAMIC**

Brushable protection against heavy wear and abrasion, pitting or corrosion, as faced in pump casings, slide bearings, funnels, pouring gates, pipes. Used to repair and restore worn areas on castings, valves or fan blades, to protect foundry or casting molds or to make jigs and fixtures. Made of ceramic and filled with high hardness silicon oxide resin, CE-SR features excellent mechanical strength, brushable liquid consistency and reduced curing time.

**ST-P STEEL PUTTY**

Steel-based putty-like compound, made of fine steel powder, anticorrosion additives and polymeric cross-linked resin. Designed for the repair or reconstruction of all metal parts. Particularly suitable for repairing corrosion problems, leaking tanks, pipes, castings, engine cases and machine parts, make models, forms, tools and holding devices. Successfully used on all metals including stainless steel. The product's high dielectric strength rejects corrosion or pitting.





## ST-L LIQUID STEEL

Steel-based compound in liquid form, made of extra-fine steel powder, anticorrosion additives and polymeric cross-linked resin. Designed for reconstruction or protection of metal parts. Recommended especially for the production of molds and forms, tools, holding devices, frames and gauges. Also suitable for filling up blowholes and micro porosities of castings. Its high dielectric strength does not allow corrosion or pitting.



## ST-HD STEEL PUTTY High Density

Pre-dosed stick of polymeric compound made of different metals which, when cut in the desired size and molded with fingers, becomes a putty which perfectly hardens in a few minutes. Suitable for repair and restoration of various metals parts. Available with steel, aluminum, copper or titanium microbeads fillers.





SEALING BEYOND EXPECTATIONS

*Sealing Devices for Rotating Equipment  
and Industrial Maintenance Solutions*

Est. 1989

in Italy

---

**CONTACT US!**



SEALTEK® srl

Via Germania, 31

35010 VIGONZA (PD) Italy

Tel. +39 049 8930536-8932178

Fax +39 049 8931723

[www.sealtek.com](http://www.sealtek.com)

e.mail: [info@sealtek.com](mailto:info@sealtek.com)

